

**petlas**



# AGRICULTURAL TIRES

**petlas**  
TRACK OF TRUST



A close-up, high-angle view of a tire tread pattern, showing the intricate design of the grooves and sipes. The tread is dark grey and set against a black background, creating a strong contrast. The pattern is curved, following the arc of the tire.

Petlas Agricultural Tires are characterized by quality workmanship, leading edge technology, unique tread designs and excellent performance offering perfect mix of quality and value.

Our success depends on exceeding the expectations of our customers and standing behind everything we do.

Our aim is to build long term relationships with our customers by providing excellent service, quality and delivering our promises.

**petlas**  
TRACK OF TRUST

# Cont

05 Size Equivalences

Speed Index 06

07 Load Index Table

Petlas AG Tires by Size 08-10

12-13 Pattern Images

Basic Tire & Rim Terms  
Dimensional Definitions Comparison of  
Radial and Bias Tire 15

16 Sidewall Marking Radial & Bias Tractor

Tractor Front 18-39

40-57 Tractor Rear





# Contents

Tractor/Harvester Radial  
Row Crop 58-99

100-125 Trailer

Harvester 126-133

134-141 Forestry & Flotation

Rims 142

145 Valves

Mounting and  
Dismounting Instructions 146  
How To Inflate A Tire?

147 Storage / Use of Liquid Ballast in Tractor Tyres





Rim size diameter	Designation in Inches	85 series	80 series tires	75 series tires	70 series tires	65 series tires	60 series tires	50-55 Series tires	Row Crop Tires 90-95 series	
16	-				<b>200/70 R16</b>					
	6.00 R16		210/80 R16		<b>240/70 R16</b>	260/65 R16				
	6.50 R16				<b>260/70 R16</b>	280/65 R16				
18	7.50 R16		250/80 R16		<b>280/70 R16</b>	320/64 R16				
	7.50 R18		250/80 R18		<b>280/70 R18</b>	320/65 R18				
20	6.50 R20				<b>260/70 R20</b>					
	7.50 R20				<b>280/70 R20</b>	340/65 R18				
	9.5 R20		<b>260/80 R20</b>		<b>300/70 R20</b>	340/65 R20				
	11.2 R20	<b>280/85 R20</b>			<b>320/70 R20</b>					
	12.4 R20	<b>320/85 R20</b>	340/80 R20	340/75 R20	<b>360/70 R20</b>	420/65 R20				
	-	250/85 R25			300/70 R24					
24	8.3 R24	<b>280/85 R20</b>			<b>320/70 R20</b>					
	9.5 R24	<b>320/85 R20</b>	340/80 R20	340/75 R20	<b>360/70 R20</b>	440/65 R20				
	-	250/85 R24			300/70 R24					
	<b>11.2 R24</b>	<b>280/85 R24</b>			<b>320/70 R24</b>	440/65 R20				
	12.4 R24	<b>320/85 R24</b>			<b>380/70 R24</b>					
	13.6 R24	<b>340/85 R24</b>			<b>360/70 R24</b>	<b>420/65 R24</b>			<b>210/95 R32</b>	8.3 R32
	14.9 R24	<b>380/85 R24</b>			<b>380/70 R24</b>	<b>440/65 R24</b>				
26	14.9 R24	<b>380/85 R24</b>			<b>420/70 R24</b>	<b>480/65 R24</b>			<b>230/95 R32</b>	9.5 R32
	16.9 R24	<b>420/85 R24</b>			<b>460/70 R24</b>				<b>270/95 R32</b>	11.2 R32
	14.9 R26				<b>480/70 R24</b>	<b>540/65 R24</b>			<b>270/95 R32</b>	11.2 R32
	16.9 R26				<b>380/70 R28</b>	<b>540/65 R24</b>			<b>230/95 R36</b>	9.5 R36
	16.9 R26				<b>480/70 R26</b>	540/65 R26			<b>270/95 R36</b>	11.2 R36
28	18.4 R26				520/70 R26	<b>540/65 R28</b>	600/60 R28	750/50 R26	<b>270/95 R36</b>	11.2 R36
	-				<b>480/70 R28</b>				<b>230/95 R36</b>	9.5 R36
	23.1 R26			<b>620/75 R26</b>	<b>600/70 R30</b>	600/65 R32		1000/50 R25		
	28 LR26			<b>620/75 R26</b>	<b>600/70 R30</b>	600/65 R32		1000/50 R25		
30	9.5 R28	250/85 R28			<b>360/70 R24</b>	<b>340/65 R28</b>				
	11.2 R28	<b>280/85 R28</b>			<b>320/70 R28</b>	440/64 R24			<b>210/95 R32</b>	8.3 R32
	12.4 R28	<b>320/85 R28</b>			<b>360/70 R28</b>	420/65 R28				
	13.6 R28	<b>340/85 R28</b>			<b>380/70 R28</b>	<b>440/65 R28</b>	480/60 R28		<b>270/95 R32</b>	11.2 R32
	14.9 R28	<b>380/85 R28</b>			<b>420/70 R28</b>	<b>480/65 R28</b>	520/60 R28		<b>230/95 R36</b>	9.5 R36
	16.9 R28	<b>420/85 R28</b>			<b>480/70 R26</b>	540/65 R26				
32	14.9 R30	<b>380/85 R30</b>			<b>480/70 R28</b>	<b>540/65 R28</b>			<b>270/95 R36</b>	11.2 R36
	16.9 R30	<b>420/85 R30</b>		480/75 R30	<b>480/70 R30</b>	<b>540/65 R30</b>	600/60 R30		<b>270/95 R38</b>	11.2 R38
	18.4 R30	<b>460/85 R30</b>			<b>520/70 R30</b>	<b>600/65 R30</b>		710/55 R30	<b>230/95 R40</b>	8.3 R44
	23.1 R30	<b>320/85 R38</b>			<b>620/70 R26</b>	600/65 R30			<b>420/90 R30</b>	
34	12.4 R32	<b>320/85 R32</b>			<b>600/70 R28</b>	<b>540/65 R38</b>	600/60 R38		<b>210/95 R44</b>	-
	24.5 R32				<b>480/70 R38</b>	<b>540/65 R38</b>			<b>270/95 R38</b>	9.5 R38
	30.5 LR32				<b>620/75 R30</b>	<b>540/65 R38</b>				
36	14.9 R34	<b>380/85 R34</b>			<b>480/70 R28</b>	<b>540/65 R28</b>			<b>270/95 R36</b>	11.2 R36
	16.9 R34	<b>420/85 R34</b>		400/75 R38	<b>480/70 R34</b>	<b>540/65 R34</b>			<b>230/95 R44</b>	9.5 R38
	18.4 R34	<b>460/85 R34</b>		520/75 R34	<b>520/70 R34</b>	<b>600/65 R34</b>			<b>270/95 R44</b>	11.2 R44
	23.1 R34			650/70 R30	<b>520/70 R38</b>	<b>600/65 R38</b>			<b>230/95 R48</b>	9.5 R48
38	-		<b>480/80 R34</b>		<b>650/75 R32</b>					
	8.3 R36	420/85 R24			<b>600/70 R34</b>	480/70 R24			<b>210/95 R36</b>	8.3 R36
	11.2 R36	320/85 R34			<b>480/70 R24</b>	540/65 R24			<b>270/95 R36</b>	11.2 R36
	12.4 R36	<b>320/85 R36</b>		480/75 R30	<b>480/70 R30</b>	<b>540/65 R30</b>	600/60 R30		<b>270/95 R38</b>	11.2 R38
	13.6 R36	<b>340/85 R36</b>			<b>520/70 R30</b>	600/65 R30		710/55 R30	<b>210/95 R44</b>	8.3 R44
	13.6 R36	<b>380/85 R34</b>			<b>600/70 R28</b>					
42	12.4 R38	<b>320/85 R38</b>			<b>620/70 R26</b>					
	13.6 R38	<b>340/85 R38</b>		400/75 R38	<b>500/70 R34</b>	<b>540/65 R34</b>			<b>230/95 R44</b>	9.5 R44
	14.9 R38	<b>380/85 R38</b>	380/80R38	520/75 R34	<b>520/70 R34</b>	<b>600/65 R34</b>				
	15.5 R38	<b>460/85 R34</b>			<b>600/70 R26</b>					
	16.9 R38	<b>340/85 R38</b>		400/75 R38	<b>500/70 R34</b>	<b>540/65 R34</b>	600/60 R38		<b>230/95 R44</b>	9.5 R44
	18.4 R38	<b>420/85 R38</b>		620/75 R30	<b>480/70 R38</b>	<b>540/65 R38</b>	650/60 R38		<b>230/95 R48</b>	9.5 R48
46	20.8 R38	<b>460/85 R38</b>	<b>480/80 R38</b>	620/75 R34	<b>520/70 R38</b>	<b>600/65 R38</b>			<b>300/95 R46</b>	12.4 R46
	20.8 R38	<b>520/85 R38</b>	<b>480/80 R42</b>	680/70 R32	<b>580/70 R38</b>	<b>650/65 R38</b>	710/60 R38	900/55 R32	<b>270/95 R48</b>	11.2 R48
	-		420/80 R46		620/70 R38	750/65 R34	900/60 R32	1050/50 R32	<b>320/90 R50</b>	
	-				620/70 R38	<b>800/65 R32</b>			<b>380/90 R46</b>	
48	18.4 R42	460/85 R42		680/75 R32	<b>600/70 R38</b>	<b>650/70 R38</b>				
	20.8 R42	<b>340/85 R48</b>			<b>580/70 R38</b>	<b>650/65 R38</b>		900/55 R32	<b>320/90 R50</b>	
	20.8 R42	<b>520/85 R42</b>	<b>480/80 R46</b>	650/75 R38	<b>580/70 R42</b>	<b>650/65 R42</b>	710/60 R42	1050/50 R32	<b>300/95 R52</b>	12.4 R52
50	-			710/75 R34	<b>620/70 R42</b>	<b>650/65 R42</b>	900/60 R32	900/50 R42	<b>270/95 R54</b>	11.2 R54
	-		<b>460/80 R42</b>		<b>710/70 R38</b>				<b>320/90 R54</b>	
	-		<b>530/80 R42</b>							
52	20.8 R46	<b>520/85 R46</b>	<b>480/80 R50</b>		<b>800/70 R38</b>	650/65 R46	900/60 R38		<b>500/95 R32</b>	-
	-	<b>650/85 R38</b>			<b>710/70 R42</b>					
2 m 15		710/85 R38		710/75 R42			900/60 R42			

Tire sizes available in Petlas Brand are in bold. The data used in these equivalences chart is based on ETRTO.

\* Tire sizes under development are marked in red in the table.

\*\* This table is only for reference; our company is not responsible for printing errors.





Speed Index	Speed, km/h
A1	5
A2	10
A3	15
A4	20
A5	25
A6	30
A7	35
A8	40
B	50
C	60
D	65
E	70
F	80
G	90
J	100
K	110
L	120
M	130
N	140
P	150
Q	160
R	170
S	180
T	190
U	200
H	210
V	240
W	270
Y	300



LI	kg	LI	kg	LI	kg	LI	kg	LI	kg	LI	kg	LI	kg
0	45	40	140	80	450	120	1400	160	4500	200	14000	240	45000
1	46,2	41	145	81	462	121	1450	161	4625	201	14500	241	46250
2	47,5	42	150	82	475	122	1500	162	4750	202	15000	242	47500
3	48,7	43	155	83	487	123	1550	163	4875	203	15500	243	48750
4	50	44	160	84	500	124	1600	164	5000	204	16000	244	50000
5	51,5	45	165	85	515	125	1650	165	5150	205	16500	245	51500
6	53	46	170	86	530	126	1700	166	5300	206	17000	246	53000
7	54,5	47	175	87	545	127	1750	167	5450	207	17500	247	54500
8	56	48	180	88	560	128	1800	168	5600	208	18000	248	56000
9	58	49	185	89	580	129	1850	169	5800	209	18500	249	58000
10	60	50	190	90	600	130	1900	170	6000	210	19000	250	60000
11	61,5	51	195	91	615	131	1950	171	6150	211	19500	251	61500
12	63	52	200	92	630	132	2000	172	6300	212	20000	252	63000
13	65	53	206	93	650	133	2060	173	6500	213	20600	253	65000
14	67	54	212	94	670	134	2120	174	6700	214	21200	254	67000
15	69	55	218	95	690	135	2180	175	6900	215	21800	255	69000
16	71	56	224	96	710	136	2240	176	7100	216	22400	256	71000
17	73	57	230	97	730	137	2300	177	7300	217	23000	257	73000
18	75	58	236	98	750	138	2360	178	7500	218	23600	258	75000
19	77,5	59	243	99	775	139	2430	179	7750	219	24300	259	77500
20	80	60	250	100	800	140	2500	180	8000	220	25000	260	80000
21	82,5	61	257	101	825	141	2575	181	8250	221	25750	261	82500
22	85	62	265	102	850	142	2650	182	8500	222	26500	262	85000
23	87,5	63	272	103	875	143	2725	183	8750	223	27250	263	87500
24	90	64	280	104	900	144	2800	184	9000	224	28000	264	90000
25	92,5	65	290	105	925	145	2900	185	9250	225	29000	265	92500
26	95	66	300	106	950	146	3000	186	9500	226	30000	266	95000
27	97,5	67	307	107	975	147	3075	187	9750	227	30750	267	97500
28	100	68	315	108	1000	148	3150	188	10000	228	31500	268	100000
29	103	69	325	109	1030	149	3250	189	10300	229	32500	269	103000
30	106	70	335	110	1060	150	3350	190	10600	230	33500	270	106000
31	109	71	345	111	1090	151	3450	191	10900	231	34500	271	109000
32	112	72	355	112	1120	152	3550	192	11200	232	35500	272	112000
33	115	73	365	113	1150	153	3650	193	11500	233	36500	273	115000
34	118	74	375	114	1180	154	3750	194	11800	234	37500	274	118000
35	121	75	387	115	1215	155	3875	195	12150	235	38750	275	121000
36	125	76	400	116	1250	156	4000	196	12500	236	40000	276	125000
37	128	77	412	117	1285	157	4125	197	12850	237	41250	277	128500
38	132	78	425	118	1320	158	4250	198	13200	238	42500	278	132000
39	136	79	437	119	1360	159	4375	199	13600	239	43750	279	136000

The load index on the sidewall of the a tire expresses the maximum load that the a tire can bear as kg, the matched figures of each load index, as kg, takes place on the chart.



**TRACTOR FRONT**

Profiles / Size	Page
<b>Front TP-8</b>	
6.00-16	21
7.50-16	21
6.00-19	21
<b>Front TD-16</b>	
5.50-16	23
6.00-16	23
6.50-16	23
7.50-16	23
6.00-19	23
6.50-20	24
7.50-20	24
<b>Front TD-17</b>	
6.00-16	27
7.50-16	27
9.00-16	27
11.00-16	27
<b>Front TD-18</b>	
6.50-16	29
7.50-18	29
7.50-20	29
<b>Front TD-25</b>	
6.00-16	31
6.50-16	31
7.50-16	31
<b>Front TD-35</b>	
10.00-16	33
<b>Front TA-60</b>	
5.00-10	35
5.00-12	35
6.5/80-12	35
7.00-12	35

Profiles / Size	Page
10.0/80-12	35
5.00-15	35
10.0/75-15.3	35
11.5/80-15.3	35
6.00-16	36
6.50-16	36
7.50-16	36
7.00-18	36
7.50-18	36
7.50-20	36
8.00-20	36
9.50-20	36
<b>Front TA-50</b>	
6.5/80-12	39
6.5/80-13	39

**TRACTOR REAR**

Profiles / Size	Page
<b>Rear TZ-13</b>	
12.4/11-28	43
16.9/14-30	43
<b>Rear TA-60</b>	
8.3-24	45
9.5-24	45
11.2-24	45
12.4-24	45
13.6-24	46
14.9-24	46
18.4-26	46
11.2-28	46
12.4-28	46
13.6-28	47
14.9-28	47
16.9-28	47
14.9-30	47

Profiles / Size	Page
16.9-30	48
18.4-30	48
12.4-32	49
16.9-34	49
18.4-34	49
12.4-36	50
13.6-36	50
13.6-38	50
14.00-38	50
15.5-38	50
16.9-38	51
18.4-38	51

**Rear TA-300**

9.5-24	53
11.2-24	53
12.4-24	53
13.6-24	53
14.9-24	53
12.4-28	53
13.6-28	53
14.9-28	54
14.9-30	54
16.9-30	54
18.4-30	54
16.9-34	54
18.4-34	54
12.4-36	55
13.6-36	55
16.9-38	55

**Rear TA-330**

30.5L-32	56
----------	----

**TRACTOR/HARVESTER RADIAL-ROW CROP**

Profiles / Size	Page
<b>Radial TA-110/65</b>	
420/65 R24	61
440/65 R24	61
480/65 R24	61
540/65 R24	61
440/65 R28	61
480/65 R28	62
540/65 R28	62
540/65 R30	62
540/65 R34	62
600/65 R34	63
540/65 R38	63
600/65 R38	63
650/65 R38	63
<b>Radial TA-110/70</b>	
200/70 R16	65
240/70 R16	65
260/70 R16	65
280/70 R16	66
280/70 R18	66
260/70 R20	66
280/70 R20	67
300/70 R20	67
320/70 R20	67
360/70 R20	68
320/70 R24	68
360/70 R24	68
380/70 R24	68
420/70 R24	69
480/70 R24	69
480/70 R26	69
320/70 R28	69
360/70 R28	70
380/70 R28	70
420/70 R28	70
480/70 R28	70
420/70 R30	70



Profiles / Size	Page
480/70 R30	70
520/70 R30	70
480/70 R34	79
520/70 R34	71
480/70 R38	71
520/70 R38	71
580/70 R38	71
580/70 R42	71
580/70 R42	71

Profiles / Size	Page
<b>Radial TA-110/80</b>	
260/80 R20	75
480/80 R38	75
480/80 R42	75
480/80 R46	75
480/80 R50	75

Profiles / Size	Page
<b>Radial TA-110/85</b>	
9.5 R20	77
9.5 R24	77
280/85 R20	77
320/85 R20	77
280/85 R24	78
320/85 R24	78
340/85 R24	78
380/85 R24	78
420/85 R24	79
280/85 R28	79
320/85 R28	79
340/85 R28	79
380/85 R28	80
420/85 R28	80
380/85 R30	80
420/85 R30	80
460/85 R30	81
320/85 R32	81
380/85 R34	81
420/85 R34	81
460/85 R34	81
320/85 R36	83
340/85 R36	83
320/85 R38	83
340/85 R38	83

Profiles / Size	Page
380/85 R38	83
420/85 R38	83
460/85 R38	83
460/85 R38	83
REINFORCED	83
520/85 R38	84
650/85 R38	84
520/85 R42	84
520/85 R42	85
REINFORCED	85
520/85 R46	85

Profiles / Size	Page
<b>Radial TA-140</b>	
340/85 R28	92

## HARVESTER-TRACTOR RADIAL

Profiles / Size	Page
<b>Radial TA-130/65</b>	
600/65 R28	87
600/65 R42	87
650/65 R42	87

Profiles / Size	Page
<b>Radial TA-130/70</b>	
600/70 R28	89
600/70 R30	89
600/70 R34	89
600/70 R34	89
710/70 R38	89
800/70 R38	89
620/70 R42	89
710/70 R42	89

Profiles / Size	Page
<b>Radial TA-130/70 IF Series</b>	
IF 600/70 R30	91
IF 800/70 R38	91
IF: Improved Flexion	

Profiles / Size	Page
<b>Radial TA-130/75 Harvester</b>	
620/75 R26 <small>AGROPER</small>	93
620/75 R30 <small>AGROPER</small>	93
650/75 R32 <small>AGROPER</small>	93

## ROW CROP

Profiles / Size	Page
<b>Radial TA-120</b>	
210/95 R32	97
230/95 R32	97
270/95 R32	97
210/95 R36	97
230/95 R36	97
270/95 R38	97
230/95 R40	98
210/95 R44	98
230/95 R44	98
270/95 R44	98
300/95 R46	98
230/95 R48	98
270/95 R48	99
270/95 R54	99
300/95 R52	99
380/90 R46	99
340/85 R48	99

## TRAILER

Profiles / Size	Page
<b>Trailer UN-1 3 Rib</b>	
7.50-16	103

Profiles / Size	Page
<b>Trailer UN-1 5 Rib</b>	
19.0/45-17	105
500/50-17	105
15.0/55-17	105
400/60-15.5	105
10.5/65-16	105
340/55-16	105
13.0/65-18	106
10.0/75-15.3	106
REINFORCED	106
10.0/75-15.3	106
11.5/80-15.3	106
REINFORCED	106

Profiles / Size	Page
11.5/80-15.3	107
12.5/80-15.3	107
REINFORCED	107
12.5/80-15.3	107
10.5/80-18	107

Profiles / Size	Page
<b>Trailer UN-3</b>	
10.0/80-12	109
11.5/80-15.3	109
11.5/80-15.3	109
REINFORCED	109
12.5/80-15.3	109
12.5/80-15.3	109
REINFORCED	109
10.0/75-15.3	109
10.0/75-15.3	109
REINFORCED	109
260/70-15.3	109

Profiles / Size	Page
-----------------	------

Profiles / Size	Page
<b>Trailer UN-5</b>	
10.0/80-12	111
REINFORCED	111
10.0/80-12	111

Profiles / Size	Page
<b>Trailer UN-7</b>	
9.5L-14SL	113
9.5L-15SL	113
11L-15SL	113
12.5L-15SL	113

Profiles / Size	Page
<b>Trailer STB-3</b>	
10.0/75-15.3	115





**HARVESTER**

**FORESTRY - FLOTATION**

Profiles / Size	Page
<b>Trailer PA-20</b>	
8.25-20	117
<b>Trailer NT-3</b>	
9.00-16	119
11.5/80-15.3	119
<b>Trailer NT-30</b>	
9.00-16	121
<b>Trailer NB-27</b>	
9.00-20	123
<b>Trailer NB-37</b>	
7.50-16	126

Profiles / Size	Page
<b>Harvester BD-60</b>	
18.4-30	129
<b>Harvester BD-65</b>	
23.1-26	131
23.1-30	131
20.8-38	131
<b>Harvester UN-1</b>	
12.5/80-18	133

Profiles / Size	Page
<b>IMF-18</b>	
12.5/80-15.3	137
400/60-15.5	137
500/60-22.5	137
550/60-22.5	137
600/50-22.5	137
<b>IMT-18</b>	
400/60-15.5	139
500/60-22.5	139
550/60-22.5	139
600/50-22.5	139

Profiles / Size	Page
<b>IMT-08</b>	
500/60-22.5	141
550/60-22.5	141
600/50-22.5	141



**Petlas Agricultural Tires: Track of Trust.**

**Petlas Agricultural Tires: Track of Trust.**

**Petlas Agricultural Tires: Track of Trust.**

**Petlas Agricultural Tires: Track of Trust.**

**Petlas Agricultural Tires: Track of Trust.**



**petlas**





• TRACTOR FRONT



TP 8



TD 16



TD 17



TD 18



TD 25



TD 35



TA 60



TA 50

• TRACTOR REAR



TA 60



TZ 13



TA 300



TA 330

• TRACTOR / HARVESTER RADIAL - ROW CROP



TA 110

Radial



TA 140

Radial



TA 130

Radial



TA 120

Radial

• TRAILER



• HARVESTER



• FORESTRY - FLOTATION







**Petlas Agricultural Tires: Designed for Power**

## BASIC TIRE & RIM TERMS

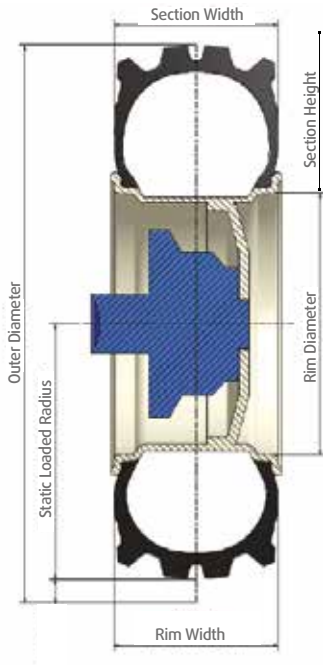

- **Outer Diameter:** The diameter of the inflated tire on recommended rim without any load.
- **Section Width:** The widest distance between the outside sidewalls of an inflated tire without any load.
- **Section Height:** The vertical distance from middle point of the tread to outer tread surface of an inflated tire without any load.
- **Static Loaded Radius:** The height between axle center and road surface of the tire under load.
- **Rim Width:** The distance between flanges of the rim.
- **Rim Diameter:** The vertical distance between the bead seat areas of the rim.
- **Dynamic Rolling Circumference:** The distance of the tire at one rotation.

## RADIAL AND BIAS TRACTOR TIRES



**Radial tire construction:**  
The cords are replaced towards the tire center with 90 degrees.



**Bias tire construction:**  
the cords are placed diagonally with certain degrees for the rotation direction of a tire.

### The Advantages of A Radial Tire

- Better grip and traction with wide tread, reduced slip
- Lower rolling resistance
- Minimized soil compaction
- Maximized life span
- Improved driving comfort with stronger and more flexible sidewall
- Lower fuel consumption
- Higher load capacity

The plies wrap the tire with an angle lower than 90° from bead to bead. Each ply or carcass cord take place in a bias position.

The plies wrap the tire with an angle of 90° from bead to bead. In addition to parallel body plies, there are also bias impact plies.



a) Radial Tractor

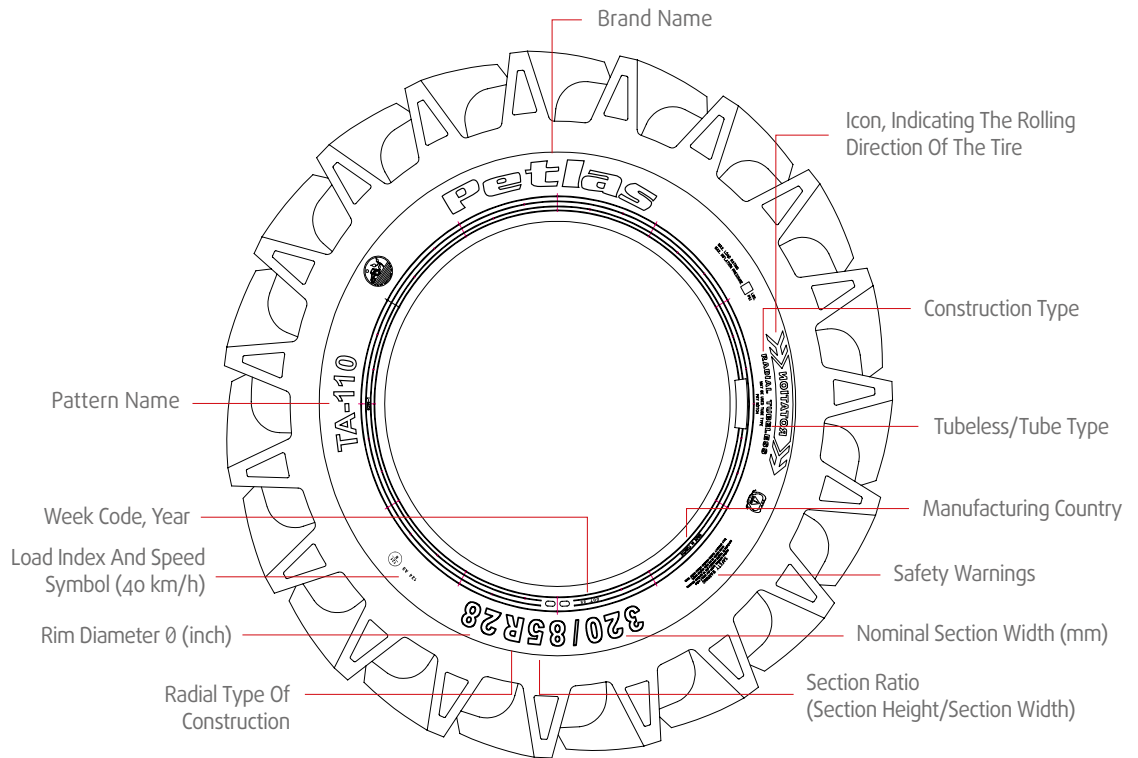

b) Bias Tractor

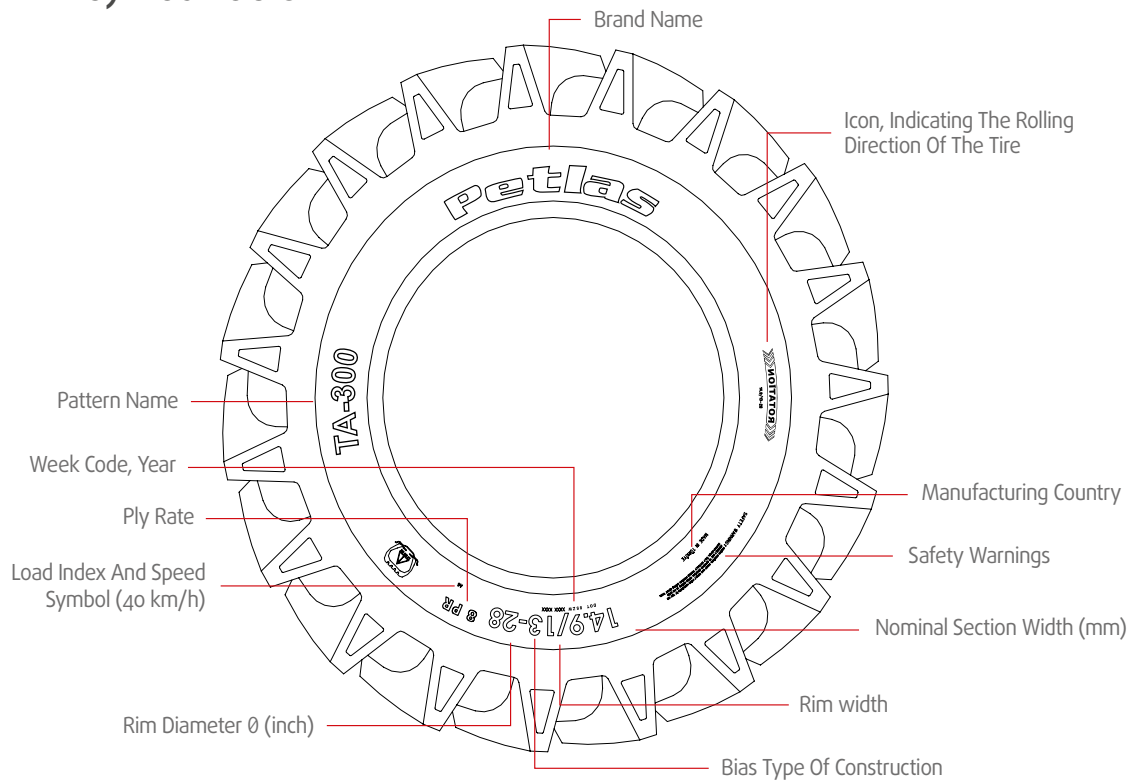



petlas



Tractor Front

TP 8

TP 8

TD 16

TD 16

TD 17

TD 18

TD 25

TD 35

TA 60

TA 50





TP 8 | TD 16 | TD 17 | TD 18 | TD 25 | TD 35 | TA 60 | TA 50





# TP 8

Tractor  
Front

## PERFORMANCE INFORMATION

Ideal tractor front tire for field and short distance road usage



## FEATURES

### Long service life / durability

- Strong nylon carcass structure provides optimum durability
- Improved tread compound provides high resistance against wear and cuts
- Strong center and shoulder design provides high resistance to side impacts and tread base fatigue

### Ease of use

- Special tread geometry provides easy steering
- Flexible carcass structure prevents sinking.

## SIZES

6.00-16 • 7.50-16 • 6.00-19

## Tractor Front · Characteristics of TP 8

Tire Size	PR	TT/TL	Load/Speed Index	Rims		Inflated Dimensions (No Load)		Inflated Dimensions (W/Load)		Inflation Pressure (psi/bar)	Load capacity per tire, kg					
				Recom (inch)	Permitted (inch)	Section Width (mm)	Outer Diameter (mm)	Dynamic Rolling Circumference (mm)	Static Loaded Radius (mm)		Speed, km/h					
											10	15	20	25	30	40
6.00-16	6	TT	88 / A6	4.50E	4.00E, 5.00F	165	735	2205	338	41 / 2.8	775	735	695	595	515	415
										45 / 3.1	825	790	745	635	550	440
										<b>48 / 3.3</b>	840	800	755	645	<b>560</b>	450
7.50-16	6	TT	98 / A6	5.50F	5.00F, 5K, 6.00F	205	805	2407	367	35 / 2.4	1050	1000	945	805	700	560
										38 / 2.6	1095	1045	985	840	730	585
										<b>41 / 2.8</b>	1125	1075	1015	865	<b>750</b>	600
	8	TT	103 / A6	45 / 3.1	1195	1140	1075	915	795	635						
				49 / 3.4	1245	1190	1120	955	830	665						
				<b>54 / 3.7</b>	1315	1250	1180	1005	<b>875</b>	700						
6.00-19	6	TT	93 / A6	4.50E	4.00E, 5.00F	165	814	2442	378	41 / 2.8	900	860	810	690	600	480
										45 / 3.1	945	900	850	725	630	505
										<b>48 / 3.3</b>	975	930	880	750	<b>650</b>	520

· Load capacity on recommended speed and pressure is stated with dark colour.

### DESCRIPTION

- \* For load capacity on various speed ratings, and inflation figures, please consult your sales representative.
- \*\* Load capacity on standard speed and weight

- Our company is entitled to make any change on any information in this catalogue, without further notice.
- This catalogue annuls all the previous catalogues
- All figures are for reference; our company is not responsible for printing errors.

# TD 16

Tractor  
Front

## PERFORMANCE INFORMATION

Ideal tractor front tire with special tread design for field and short distance road usage



## FEATURES

### Long service life / Durability

- Strong nylon carcass structure provides optimum durability
- Improved tread compound provides high resistance against wear and cuts
- Strong center and shoulder design provides high resistance to side impacts and tread base fatigue

### Ease of use

- Special tread geometry provides easy steering
- Flexible carcass structure prevents sinking.

### Self cleaning

- Special tread design provides efficient self cleaning

**SIZES** 5.50-16 • 6.00-16 • 6.50-16 • 7.50-16 • 6.00-19 • 6.50-20 • 7.50-20



## Tractor Front • Characteristics of TD 16

Tire Size	PR	TT/TL	Load/Speed Index	Rims		Inflated Dimensions (No Load)		Inflated Dimensions (W/Load)		Inflation Pressure (psi/bar)	Load capacity per tire, kg					
				Recom (inch)	Permitted (inch)	Section Width (mm)	Outer Diameter (mm)	Dynamic Rolling Circumference (mm)	Static Loaded Radius (mm)		Speed, km/h					
											10	15	20	25	30	40
5.50-16	6	TT	86 / A6	4.00E	3.50D, 4.50E	150	710	2130	329	45 / 3.1	745	710	670	570	495	395
										49 / 3.4	775	735	695	595	515	415
										<b>54 / 3.7</b>	795	760	715	610	<b>530</b>	425
6.00-16	6	TT	88 / A6	4.50E	4.00E, 5.00F	165	735	2205	338	41 / 2.8	775	735	695	595	515	410
										45 / 3.1	825	790	745	635	550	440
										<b>48 / 3.3</b>	840	800	755	645	<b>560</b>	450
6.50-16	6	TT	91 / A6	4.50E	4.00E, 5K, 5.50F, 5.50F	175	760	2280	350	38 / 2.6	850	810	765	650	565	450
										42 / 2.9	915	875	825	705	610	485
										<b>45 / 3.1</b>	925	880	830	710	<b>615</b>	495
	8	TT	97 / A6	52 / 3.6	1005	960	905	770	670	535						
				<b>61 / 4.2</b>	1095	1045	985	840	<b>730</b>	585						
7.50-16	6	TT	98 / A6	5.50F	5.00F, 5K, 6.00F	205	805	2415	367	35 / 2.4	1050	1000	945	805	700	560
										38 / 2.6	1095	1045	985	840	730	585
										<b>41 / 2.8</b>	1125	1075	1015	865	<b>750</b>	600
	8	TT	103 / A6	45 / 3.1	1210	1150	1085	925	805	645						
				<b>54 / 3.7</b>	1250	1250	1180	1005	<b>875</b>	700						
6.00-19	6	TT	93 / A6	4.50E	4.00E, 5.00F	165	814	2442	378	41 / 2.8	900	860	810	690	600	480
										45 / 3.1	955	910	860	730	635	510
										<b>48 / 3.3</b>	975	930	880	750	<b>650</b>	520

• Load capacity on recommended speed and pressure is stated with dark colour.

### DESCRIPTION

- \* For load capacity on various speed ratings, and inflation figures, please consult your sales representative.
- \*\* Load capacity on standard speed and weight

- Our company is entitled to make any change on any information in this catalogue, without further notice.
- This catalogue annuls all the previous catalogues
- All figures are for reference; our company is not responsible for printing errors.



## Tractor Front • Characteristics of TD 16

Tire Size	PR	TT/TL	Load/Speed Index	Rims		Inflated Dimensions (No Load)		Inflated Dimensions (W/Load)		Inflation Pressure (psi/bar)	Load capacity per tire, kg					
				Recom (inch)	Permitted (inch)	Section Width (mm)	Outer Diameter (mm)	Dynamic Rolling Circumference (mm)	Static Loaded Radius (mm)		Speed, km/h					
											10	15	20	25	30	40
650-20	8	TT	108 / A6	5.00F	4.00E, 5.50F	175	865	2595	402	45 / 3.1	1395	1330	1255	1070	930	745
										49 / 3.4	1455	1385	1310	1115	970	775
										<b>54 / 3.7</b>	1500	1430	1350	1150	<b>1000</b>	800
	10	TT	115 / A6			165				54 / 3.7	1660	1580	1490	1270	1105	885
										58 / 4.0	1730	1650	1560	1325	1155	925
										62 / 4.3	1820	1735	1640	1400	1215	970
750-20	8	TT	108 / A6	5.50F	5.00F	205	915	2727	420	42 / 2.9	1380	1315	1245	1260	920	735
										45 / 3.1	1440	1375	1295	1105	960	770
										<b>49 / 3.4</b>	1500	1430	1350	1150	<b>1000</b>	800
	10	TT	115 / A6			214				49 / 3.4	1660	1580	1490	1270	1105	885
										54 / 3.7	1730	1650	1560	1325	1155	925
										<b>58 / 4.0</b>	1820	1735	1640	1400	<b>1215</b>	970

• Load capacity on recommended speed and pressure is stated with dark colour.

### DESCRIPTION

\* For load capacity on various speeds, and inflation figures, please consult your sales representative.

\*\* Load capacity on standard speed and weight

- Our company is entitled to make any change on any information in this catalogue, without further notice.
- This catalogue annuls all the previous catalogues
- All figures are for reference; our company is not responsible for printing errors.







**Petlas Agricultural Tires: Footprint of Your Confidence.**

**petlas**

# TD 17

Tractor  
Front

## PERFORMANCE INFORMATION

Farm front tire with strong carcass structure



## FEATURES

### Long service life / Durability

- Strong nylon carcass structure provides optimum durability
- Improved tread compound provides high resistance against wear and cuts
- Strong center and shoulder design provides high resistance to side impacts and tread base fatigue

### Ease of use

- Special tread geometry provides easy steering
- Flexible carcass structure prevents sinking

### Self cleaning

- Special tread design provides efficient self cleaning

## SIZES

6.00-16 • 7.50-16 • 9.00-16 • 11.00-16



## Tractor Front • Characteristics of TD 17

Tire Size	PR	TT/TL	Load/Speed Index	Rims		Inflated Dimensions (No Load)		Inflated Dimensions (W/Load)		Inflation Pressure (psi/bar)	Load capacity per tire, kg					
				Recom (inch)	Permitted (inch)	Section Width (mm)	Outer Diameter (mm)	Dynamic Rolling Circumference (mm)	Static Loaded Radius (mm)		Speed, km/h					
											10	15	20	25	30	40
6.00-16	6	TT	88 / A6	4.50E	4.00E, 5.00F	165	735	2205	338	41 / 2.8	775	735	695	595	515	410
										45 / 3.1	815	770	730	620	540	430
										<b>48 / 3.3</b>	840	800	755	645	<b>560</b>	450
7.50-16	8	TT	103 / A6	5.50F	5.00F, 5K, 6.00F	205	805	2415	367	45 / 3.1	1210	1150	1085	925	805	645
										49 / 3.4	1275	1215	1150	980	850	680
										<b>54 / 3.7</b>	1250	1250	1180	1005	<b>875</b>	700
9.00-16	8	TT	111 / A6	W8	6.00F, W7, W8L	234	855	2556	392	38 / 2.6	1495	1425	1345	1145	995	795
										42 / 2.9	1565	1495	1410	1205	1045	835
										<b>45 / 3.1</b>	1635	1560	1475	1255	<b>1090</b>	875
11.00-16	8	TT	118 / A6	WW10L	W8, W8L	315	965	2876	437	30 / 2.1	1845	1760	1660	1415	1230	985
										33 / 2.3	1900	1810	1710	1455	1265	1015
										<b>36 / 2.5</b>	1980	1890	1780	1520	<b>1320</b>	1055

• Load capacity on recommended speed and pressure is stated with dark colour.

### DESCRIPTION

\* For load capacity on various speed ratings, and inflation figures, please consult your sales representative.

\*\* Load capacity on standard speed and weight

- Our company is entitled to make any change on any information in this catalogue, without further notice.
- This catalogue annuls all the previous catalogues
- All figures are for reference; our company is not responsible for printing errors.

# TD 18

Tractor  
Front

## PERFORMANCE INFORMATION

Ideal tractor front tire for field and short distance road usage



## FEATURES

### Long service life / Durability

- Strong nylon carcass structure provides optimum durability
- Improved tread compound provides high resistance against wear and cuts
- Strong center and shoulder design provides high resistance to side impacts and tread base fatigue

### Ease of use

- Special tread geometry provides easy steering
- Flexible carcass structure prevents sinking

**SIZES** 6.50-16 • 7.50-18 • 7.50-20

## Tractor Front - Characteristics of TD 18

Tire Size	PR	TT/TL	Load/Speed Index	Rims		Inflated Dimensions (No Load)		Inflated Dimensions (W/Load)		Inflation Pressure (psi/bar)	Load capacity per tire, kg					
				Recom (inch)	Permitted (inch)	Section Width (mm)	Outer Diameter (mm)	Dynamic Rolling Circumference (mm)	Static Loaded Radius (mm)		Speed, km/h					
											10	15	20	25	30	40
6.50-16	6	TT	91 / A6	4.50E	4.00E, 5K, 5.50F, 5.50F	175	760	2280	350	38 / 2.6	840	800	755	645	560	450
										41 / 2.8	890	845	800	680	590	475
										<b>45 / 3.1</b>	925	880	830	705	<b>615</b>	495
	8	TT	97 / A6	5.50F	-	205	860	2580	396	52 / 3.6	1015	965	910	775	675	540
										57 / 3.9	1050	1000	945	805	700	560
<b>61 / 4.2</b>	1095	1045	985	840	<b>730</b>	585										
7.50-18	8	TT	106 / A6	5.50F	-	205	860	2580	396	45 / 3.1	1325	1265	1195	1020	885	710
										49 / 3.4	1390	1325	1250	1065	925	740
										<b>54 / 3.7</b>	1425	1360	1285	1095	<b>950</b>	760
7.50-20	8	TT	108 / A6	5.50F	5.00F	205	915	2727	420	42 / 2.9	1380	1315	1245	1060	920	735
										45 / 3.1	1440	1375	1295	1105	960	770
										<b>49 / 3.4</b>	1500	1430	1350	1150	<b>1000</b>	800

• Load capacity on recommended speed and pressure is stated with dark colour.

### DESCRIPTION

\* For load capacity on various speed ratings, and inflation figures, please consult your sales representative.

\*\* Load capacity on standard speed and weight

- Our company is entitled to make any change on any information in this catalogue, without further notice.
- This catalogue annuls all the previous catalogues
- All figures are for reference; our company is not responsible for printing errors.



# TD 25

Tractor  
Front

## PERFORMANCE INFORMATION

Ideal tractor front tire with special tread design for field and short distance road usage.



## FEATURES

### Long service life / Durability

- Strong nylon carcass structure provides optimum durability
- Improved tread compound provides high resistance against wear and cuts
- Strong center and shoulder design provides high resistance to side impacts and tread base fatigue

### Ease of use

- Special tread geometry provides easy steering
- Flexible carcass structure prevents sinking

### Self cleaning

- Special tread design provides efficient self cleaning

**SIZES** 6.00-16 • 6.50-16 • 7.50-16

## Tractor Front • Characteristics of TD 25

Tire Size	PR	TT/TL	Load/Speed Index	Rims		Inflated Dimensions (No Load)		Inflated Dimensions (W/Load)		Inflation Pressure (psi/bar)	Load capacity per tire, kg					
				Recom (inch)	Permitted (inch)	Section Width (mm)	Outer Diameter (mm)	Dynamic Rolling Circumference (mm)	Static Loaded Radius (mm)		Speed, km/h					
											10	15	20	25	30	40
6.00-16	6	TT	88 / A6	4.50E	4.00E, 5.00F	165	735	2205	338	41 / 2.8	775	735	695	595	515	415
										45 / 3.1	810	785	720	615	540	430
										<b>48 / 3.3</b>	840	800	755	645	<b>560</b>	450
	68 / 4.7	1070	1020							960	820	710	570			
	73 / 5.0	1100	1050							990	845	735	590			
10	TT	98 / A6	<b>80 / 5.5</b>	1125	1070	1010	860	<b>750</b>	600							
6.50-16	6	TT	91 / A6	4.50E	4.00E, 5K, 5.50F, 5.50F	175	760	2280	350	38 / 2.6	840	800	755	645	560	445
										42 / 2.9	885	840	795	680	590	470
										<b>45 / 3.1</b>	920	880	830	710	<b>615</b>	490
	52 / 3.6	1015	965							910	775	675	540			
	57 / 3.9	1050	1000							945	805	700	560			
8	TT	97 / A6	<b>61 / 4.2</b>	1095	1045	985	840	<b>730</b>	585							
7.50-16	8	TT	103 / A6	5.50F	5.00F, 5K, 6.00F	205	805	2407	367	45 / 3.1	1195	1135	1075	915	795	635
										49 / 3.4	1245	1185	1120	955	830	665
										<b>54 / 3.7</b>	1315	1250	1180	1005	<b>875</b>	700

\* Load capacity on recommended speed and pressure is stated with dark colour.

### DESCRIPTION

- \* For load capacity on various speed ratings, and inflation figures, please consult your sales representative.
- \*\* Load capacity on standard speed and weight

- Our company is entitled to make any change on any information in this catalogue, without further notice.
- This catalogue annuls all the previous catalogues
- All figures are for reference; our company is not responsible for printing errors.

# TD 35

Tractor  
Front

## PERFORMANCE INFORMATION

Farm front tire with strong carcass structure



## FEATURES

### Long service life / Durability

- Strong nylon carcass structure provides optimum durability
- Improved tread compound provides high resistance against wear and cuts
- Strong center and shoulder design provides high resistance to side impacts and tread base fatigue

### Ease of use

- Special tread geometry provides easy steering
- Flexible carcass structure prevents sinking

### Self cleaning

- Special tread design provides efficient self cleaning

## SIZES 10.00-16



## Tractor Front • Characteristics of **TD 35**

Tire Size	PR	TT/TL	Load/Speed Index	Rims		Inflated Dimensions (No Load)		Inflated Dimensions (W/Load)		Inflation Pressure (psi/bar)	Load capacity per tire, kg					
				Recom (inch)	Permitted (inch)	Section Width (mm)	Outer Diameter (mm)	Dynamic Rolling Circumference (mm)	Static Loaded Radius (mm)		Speed, km/h					
											10	15	20	25	30	40
10.00-16	8	TT	114 / A6	W8	W8L	274	895	2667	404	35 / 2.4	1645	1565	1480	1260	1095	875
										38 / 2.6	1715	1635	1545	1315	1145	915
										<b>41 / 2.8</b>	<b>1770</b>	<b>1685</b>	<b>1595</b>	<b>1355</b>	<b>1180</b>	<b>945</b>

• Load capacity on recommended speed and pressure is stated with dark colour.

### DESCRIPTION

\* For load capacity on various speed ratings, and inflation figures, please consult your sales representative.

\*\* Load capacity on standard speed and weight

- Our company is entitled to make any change on any information in this catalogue, without further notice.
- This catalogue annuls all the previous catalogues
- All figures are for reference; our company is not responsible for printing errors.

# TA 60

Tractor  
Front

## PERFORMANCE INFORMATION

High traction R1 farm front tire for standard field operations



## FEATURES

### Long service life / Durability

- Strong nylon carcass structure provides optimum durability
- Special tread compound provides high resistance against wear and cuts
- Tread profile provides high resistance to tread base fatigue

### Ease of use

- Wide and strong body provides easy grip and high traction
- Special tread geometry provides efficient self-cleaning

## SIZES

5.00-10 • 5.00-12 • 6.5/80-12 • 7.00-12 • 10.0/80-12 • 5.00-15 • 10.0/75-15.3 • 11.5/80-15.3  
6.00-16 • 6.50-16 • 7.50-16 • 7.00-18 • 7.50-18 • 7.50-20 • 8.00-20 • 9.50-20



## Tractor Front • Characteristics of TA 60

Tire Size	PR	TT/TL	Load/Speed Index	Rims		Inflated Dimensions (No Load)		Inflated Dimensions (W/Load)		Inflation Pressure (psi/bar)	Load capacity per tire, kg					
				Recom (inch)	Permitted (inch)	Section Width (mm)	Outer Diameter (mm)	Dynamic Rolling Circumference (mm)	Static Loaded Radius (mm)		Speed, km/h					
											10	15	20	25	30	40
5.00-10	4	TT	70-58 / A6	4J	3.5B	140	512	1526	241	25 / 1.7	475	450	425	360	315	250
										26 / 1.8	485	465	435	370	325	260
										<b>29 / 2.0</b>	505	480	450	385	<b>335</b>	270
5.00-12	4	TT	62 / A6	3.50D	3.00D, 4.00E, 4J	145	567	1690	267	26 / 1.8	370	350	330	285	245	195
										29 / 2.0	385	365	345	295	255	205
										<b>33 / 2.3</b>	400	380	360	305	<b>265</b>	215
6.5/80-12	6	TT	80 / A6	5J	5JA	163	588	1707	270	44 / 3.0	625	595	560	480	415	335
										48 / 3.3	655	625	590	500	435	350
										<b>52 / 3.6</b>	675	645	610	520	<b>450</b>	360
7.00-12	6	TT	83 / A6	4,25	-	200	667	1988	301	30 / 2.1	685	650	615	525	455	365
										33 / 2.3	705	675	635	540	470	375
										<b>36 / 2.5</b>	730	700	660	560	<b>487</b>	390
10.0/80-12	6	TT / TL	98 / A6	9.00	700	264	730	2175	327	28 / 1.9	1060	1010	950	810	705	565
										30 / 2.1	1095	1045	985	840	730	585
										<b>33 / 2.3</b>	1125	1075	1015	865	<b>750</b>	600
5.00-15	6	TT	88 / A6	4.00E	3.00D, 4J, 41/2	145	657	1952	305	44 / 3.0	780	745	705	600	520	415
										46 / 3.2	810	775	730	620	540	430
										<b>51 / 3.5</b>	840	800	755	645	<b>560</b>	450
10.0/75-15.3	12	TT	114 / A6	9.00	-	264	780	2265	360	58 / 4.0	1615	1535	1450	1235	1075	860
										64 / 4.4	1680	1605	1515	1300	1120	895
										<b>68 / 4.7</b>	1770	1685	1595	1355	<b>1180</b>	945
11.5/80-15.3	12	TT / TL	123 / A6	9.00	-	290	867	2518	391	51 / 3.5	2115	2015	1905	1625	1410	1130
										54 / 3.7	2215	2110	1990	1695	1475	1180
										<b>59 / 4.1</b>	2325	2215	2095	1785	<b>1550</b>	1240

• Load capacity on recommended speed and pressure is stated with dark colour.

### DESCRIPTION

\* For load capacity on various speed ratings, and inflation figures, please consult your sales representative.

\*\* Load capacity on standard speed and weight

- Our company is entitled to make any change on any information in this catalogue, without further notice.
- This catalogue annuls all the previous catalogues
- All figures are for reference; our company is not responsible for printing errors.

## Tractor Front • Characteristics of TA 60

Tire Size	PR	TT/TL	Load/Speed Index	Rims		Inflated Dimensions (No Load)		Inflated Dimensions (W/Load)		Inflation Pressure (psi/bar)	Load capacity per tire, kg					
				Recom (inch)	Permitted (inch)	Section Width (mm)	Outer Diameter (mm)	Dynamic Rolling Circumference (mm)	Static Loaded Radius (mm)		Speed, km/h					
											10	15	20	25	30	40
6.00-16	6	TT	88 / A6	4.50E	4.00E, 5K,5.00F	165	735	2190	340	41 / 2.8	775	735	695	595	515	415
										45 / 3.1	810	775	730	620	540	435
										<b>48 / 3.3</b>	840	800	755	645	<b>560</b>	450
6.50-16	6	TT	91 / A6	4.50E	4.00E, 5K,5.00F, 5.50F	175	760	2265	348	39 / 2.7	865	825	775	660	575	460
										42 / 2.9	885	845	800	680	590	475
										<b>45 / 3.1</b>	925	880	830	705	<b>615</b>	495
7.50-16	8	TT	103 / A6	5.50F	5.00F, 5K,6.00F	205	805	2399	367	45 / 3.1	1225	1165	1100	940	815	655
										49 / 3.4	1275	1215	1150	980	850	680
										<b>54 / 3.7</b>	1315	1250	1180	1005	<b>875</b>	700
7.00-18	8	TT	106 / A6	5.50F	5.00F	200	846	2425	375	33 / 2.3	1315	1250	1180	1005	875	700
										36 / 2.5	1375	1310	1235	1055	915	735
										<b>39 / 2.7</b>	1425	1360	1285	1095	<b>950</b>	760
7.50-18	8	TT	106 / A6	5.50F	-	205	860	2563	398	45 / 3.1	1330	1265	1195	1020	885	710
										49 / 3.4	1390	1325	1250	1065	925	740
										<b>54 / 3.7</b>	1425	1360	1285	1095	<b>950</b>	760
7.50-20	8	TT	108 / A6	5.50F	5.00F	205	915	2727	421	42 / 2.9	1380	1315	1245	1060	920	735
										45 / 3.1	1440	1375	1300	1105	960	770
										<b>49 / 3.4</b>	1500	1430	1350	1150	<b>1000</b>	800
8.00-20	8	TT	113/ A6	600	-	220	965	2880	431	33 / 2.3	1590	1515	1430	1220	1060	845
										36 / 2.5	1655	1580	1495	1270	1105	885
										<b>40 / 2.8</b>	1725	1645	1555	1325	<b>1150</b>	920
9.50-20	8	TT	107 / A6	W8	W7	241	945	2816	459	33 / 2.3	1350	1290	1215	1035	900	720
										36 / 2.5	1410	1345	1270	1080	940	750
										<b>40 / 2.8</b>	1465	1395	1315	1120	<b>975</b>	780

• Load capacity on recommended speed and pressure is stated with dark colour.

### DESCRIPTION

\* For load capacity on various speed ratings, and inflation figures, please consult your sales representative.

\*\* Load capacity on standard speed and weight

- Our company is entitled to make any change on any information in this catalogue, without further notice.
- This catalogue annuls all the previous catalogues
- All figures are for reference; our company is not responsible for printing errors.



**Petlas Agricultural Tires: Strong, Durable Tires for Professionals.**



**petlas**



# TA 50

Tractor  
Front

## PERFORMANCE INFORMATION

High traction R1 farm front tire for orchard tractors



## FEATURES

### Long service life / Durability

- Strong nylon carcass structure provides optimum durability
- Special tread compound provides high resistance against wear and cuts
- Tread profile provides high resistance to tread base fatigue

### Ease of use

- Wide and strong body provides easy grip and high traction
- Special tread geometry provides efficient self-cleaning

## SIZES

6.5/80-12 • 6.5/80-13



## Tractor Front - Characteristics of TA 50

Tire Size	PR	TT/TL	Load/Speed Index	Rims		Inflated Dimensions (No Load)		Inflated Dimensions (W/Load)		Inflation Pressure (psi/bar)	Load capacity per tire, kg					
				Recom (inch)	Permitted (inch)	Section Width (mm)	Outer Diameter (mm)	Dynamic Rolling Circumference (mm)	Static Loaded Radius (mm)		Speed, km/h					
											10	15	20	25	30	40
6.5/80-12	6	TT/TL	80 / A6	5J	5JA	175	630	1735	274	44 / 3.0	625	595	560	480	415	335
										48 / 3.3	655	625	590	500	435	350
										<b>52 / 3.6</b>	675	645	610	520	<b>450</b>	360
6.5/80-13	6	TT	94 / A6	5J	5JA	171	642	1765	280	44 / 3.0	931	886	834	715	618	499
										48 / 3.3	975	931	878	745	648	521
										<b>52 / 3.6</b>	1005	960	908	774	<b>670</b>	536

• Load capacity on recommended speed and pressure is stated with dark colour.



### DESCRIPTION

\* For load capacity on various speed ratings, and inflation figures, please consult your sales representative.

\*\* Load capacity on standard speed and weight

- Our company is entitled to make any change on any information in this catalogue, without further notice.
- This catalogue annuls all the previous catalogues
- All figures are for reference; our company is not responsible for printing errors.

**petlas**





Tractor Rear

TZ 13

TA 60

TA 300

TA 330



TZ 13 | TA 60 | TA 300 | TA 330

**petlas**





# TZ 13

Tractor  
Rear

## PERFORMANCE INFORMATION

High traction R1 farm rear tire for standard field operations and for applications on sloping terrains



## FEATURES

### Long service life / Durability

- Strong nylon carcass structure provides optimum durability
- Special tread compound provides high resistance against wear and cuts
- Tread profile provides high resistance to tread base fatigue

### Ease of use

- Wide and strong body provides easy grip and high traction
- Special tread geometry provides efficient self-cleaning

**SIZES** 12.4-28 • 16.9-30



## Tractor Rear • Characteristics of TZ 13

Tire Size	PR	TT/TL	Load/Speed Index	Rims		Inflated Dimensions (No Load)		Inflated Dimensions (W/Load)		Inflation Pressure (psi/bar)	Load capacity per tire, kg					
				Recom (inch)	Permitted (inch)	Section Width (mm)	Outer Diameter (mm)	Dynamic Rolling Circumference (mm)	Static Loaded Radius (mm)		Speed, km/h					
											10	15	20	25	30	40
12.4-28	6	TT	117 / A6	W11	W9, W10	315	1260	3755	576	20 / 1.4	1640	1520	1410	1250	1170	1055
										22 / 1.5	1710	1590	1470	1305	1220	1100
										<b>25 / 1.7</b>	1800	1670	1545	1375	<b>1285</b>	1160
	8	TT	122 / A6							29 / 2.0	1995	1855	1710	1525	1425	1285
										32 / 2.2	2060	1910	1765	1575	1470	1325
										<b>33 / 2.3</b>	2100	1950	1800	1605	<b>1500</b>	1350
16.9-30	8	TT	137 / A6	W15L	W14L	429	1485	4425	671	20 / 1.4	2930	2720	2515	2240	2095	1885
										22 / 1.5	3060	2840	2625	2340	2185	1970
										<b>25 / 1.7</b>	3220	2990	2760	2460	<b>2300</b>	2070
	10	TT	139 / A6							26 / 1.8	3200	2970	2745	2445	2285	2060
										28 / 1.9	3340	3100	2860	2550	2380	2145
										<b>30 / 2.1</b>	3405	3160	2920	2600	<b>2430</b>	2190
	12	TT	144 / A6							29 / 2.0	5640	3948	3384	3017	2820	2538
										32 / 2.2	5880	4116	3528	3146	2940	2646
										<b>35 / 2.4</b>	6000	4200	3600	3210	<b>3000</b>	2700

• Load capacity on recommended speed and pressure is stated with dark colour.

### DESCRIPTION

\* For load capacity on various speed ratings, and inflation figures, please consult your sales representative.

\*\* Load capacity on standard speed and weight

- Our company is entitled to make any change on any information in this catalogue, without further notice.
- This catalogue annuls all the previous catalogues
- All figures are for reference; our company is not responsible for printing errors.

# TA 60

Tractor  
Rear

## PERFORMANCE INFORMATION

High traction R1 farm rear tire for standard field operations



## FEATURES

### Long service life / Durability

- Strong nylon carcass structure provides optimum durability
- Special tread compound provides high resistance against wear and cuts
- Tread profile provides high resistance to tread base fatigue

### Ease of use

- Wide and strong body provides easy grip and high traction
- Special tread geometry provides efficient self-cleaning

## SIZES

8.3-24 • 9.5-24 • 11.2-24 • 12.4-24 • 13.6-24 • 14.9-24 • 18.4-26 • 11.2-28 • 12.4-28  
13.6-28 • 14.9-28 • 16.9-28 • 14.9-30 • 16.9-30 • 18.4-30 • 12.4-32 • 16.9-34 • 18.4-34  
12.4-36 • 13.6-36 • 13.6-38 • 14.00-38 • 15.5-38 • 16.9-38 • 18.4-38



## Tractor Rear • Characteristics of TA 60

Tire Size	PR	TT/TL	Load/Speed Index	Rims		Inflated Dimensions (No Load)		Inflated Dimensions (W/Load)		Inflation Pressure (psi/bar)	Load capacity per tire, kg					
				Recom (inch)	Permitted (inch)	Section Width (mm)	Outer Diameter (mm)	Dynamic Rolling Circumference (mm)	Static Loaded Radius (mm)		Speed, km/h					
											10	15	20	25	30	40
8.3-24	8	TT	108 / A6	W7	W6	211	995	2965	455	36 / 2.7	1275	1185	1090	975	910	2305
										32 / 2.2	1320	1225	1130	1005	940	2375
										<b>35 / 2.4</b>	1400	1300	1200	1070	<b>1000</b>	2450
9.5-24	8	TT	112 / A6	W8	W7	24	1050	3129	481	33 / 2.3	1430	1325	1225	1095	1020	920
										36 / 2.5	1495	1385	1280	1065	1065	960
										<b>41 / 2.8</b>	1570	1455	1345	1120	<b>1120</b>	1010
11.2-24	8	TT	116 / A6	W10	W9	284	1105	3293	503	29 / 2.0	1630	1510	1395	1245	1165	1050
										32 / 2.2	1680	1560	1440	1290	1200	1080
										<b>35 / 2.4</b>	1750	1625	1500	1340	<b>1250</b>	1125
13.6-24	8	TT	123 / A6	DW12	DW11	345	1190	3576	541	25 / 1.7	2040	1895	1750	1560	1460	1310
										28 / 1.9	2085	1935	1790	1595	1490	1340
										<b>29 / 2.0</b>	2170	2015	1860	1660	<b>1550</b>	1395
12.4-24	6	TT	115 / A6	W11	W9, W10	315	1160	3457	525	20 / 1.4	1550	1440	1330	1185	1110	995
										22 / 1.5	1615	1500	1390	1235	1155	1040
										<b>25 / 1.7</b>	1700	1580	1460	1300	<b>1215</b>	1095
	8	TT	120 / A6							29 / 2.0	1860	1730	1600	1425	1330	1200
										32 / 2.2	1920	1785	1650	1470	1730	1235
										<b>33 / 2.3</b>	1960	1820	1680	1500	<b>1800</b>	1260
	12	TT	128 / A6							44 / 3.0	2345	2175	2010	1120	1675	1505
										46 / 3.2	2420	2245	2075	1155	1730	1555
										<b>51 / 3.5</b>	2520	2340	2160	1200	<b>1800</b>	1620

• Load capacity on recommended speed and pressure is stated with dark colour.

### DESCRIPTION

\* For load capacity on various speed ratings, and inflation figures, please consult your sales representative.

\*\* Load capacity on standard speed and weight

- Our company is entitled to make any change on any information in this catalogue, without further notice.
- This catalogue annuls all the previous catalogues
- All figures are for reference; our company is not responsible for printing errors.

## Tractor Rear • Characteristics of TA 60

Tire Size	PR	TT/TL	Load/Speed Index	Rims		Inflated Dimensions (No Load)		Inflated Dimensions (W/Load)		Inflation Pressure (psi/bar)	Load capacity per tire, kg					
				Recom (inch)	Permitted (inch)	Section Width (mm)	Outer Diameter (mm)	Dynamic Rolling Circumference (mm)	Static Loaded Radius (mm)		Speed, km/h					
											10	15	20	25	30	40
14.9-24	4	TL / TT	112 / A6	W13	W11, W12	378	1265	3770	567	-	-	-	-	-	-	
										10 / 0.7	1495	1385	1280	1140	1065	960
	<b>12 / 0.8</b>	1570	1455							1345	1200	<b>1120</b>	1010			
	15 / 1.0	1780	1650							1525	1361	1270	1145			
	17 / 1.2	1975	1835							1695	1510	1410	1270			
	<b>20 / 1.4</b>	2170	2015							1860	1660	<b>1550</b>	1395			
	22 / 1.5	2370	2200							2030	1810	1695	1525			
	23 / 1.6	2420	2245							2075	1850	1730	1555			
	<b>26 / 1.8</b>	2520	2340							2160	1925	<b>1800</b>	1620			
	35 / 2.4	2825	2620							2420	2160	2015	1815			
	39 / 2.7	2910	2700							2495	2225	2080	1875			
	<b>43 / 3.0</b>	2970	2755							2545	2270	<b>2120</b>	1910			
	41 / 2.8	3190	2965							2735	2445	2280	2050			
	46 / 3.2	3490	3240							2990	2670	2490	2245			
<b>52 / 3.6</b>	3710	3445	3180	2840	<b>2650</b>	2385										
18.4-26	12	TT/ TL	146 / A6	W16L	W15L	467	1450	4321	647	29 / 2.0	3990	3705	3420	3050	2850	2565
										32 / 2.2	4115	3825	3530	3145	2940	2645
										<b>33 / 2.3</b>	4200	3900	3600	3210	<b>3000</b>	2700
	35 / 2.4	4235	3930							3630	3240	3025	2720			
	38 / 2.6	4415	4100							3785	3380	3155	2840			
	<b>41 / 2.8</b>	4550	4225							3900	3480	<b>3250</b>	2925			
11.2-28	8	TT	118 / A6	W10	W9	284	1205	3591	554	29 / 2.0	1720	1595	1475	1320	1230	1105
										32 / 2.2	1780	1645	1525	1360	1270	1140
										<b>35 / 2.4</b>	1850	1715	1585	1415	<b>1320</b>	1190
12.4-28	6	TT	117 / A6	W11	W9, W10	315	1260	3755	576	20 / 1.4	1640	1520	1405	1250	1170	1050
										22 / 1.5	1710	1590	1470	1305	1220	1100
										<b>25 / 1.7</b>	1800	1670	1545	1375	<b>1285</b>	1160
	29 / 2.0	1995	1855							1710	1525	1425	1285			
	32 / 2.2	2060	1910							1765	1575	1470	1325			
	<b>33 / 2.3</b>	2100	1950							1800	1605	<b>1500</b>	1350			

• Load capacity on recommended speed and pressure is stated with dark colour.



## Tractor Rear • Characteristics of TA 60

Tire Size	PR	TT/TL	Load/Speed Index	Rims		Inflated Dimensions (No Load)		Inflated Dimensions (W/Load)		Inflation Pressure (psi/bar)	Load capacity per tire, kg					
				Recom (inch)		Section Width (mm)	Outer Diameter (mm)	Dynamic Rolling Circumference (mm)	Static Loaded Radius (mm)		Speed, km/h					
											10	15	20	25	30	40
13.6-28	6	TT	121 / A6	W12	W11	345	1310	3904	596	20 / 1.4	1850	1715	1585	1415	1320	1190
										22 / 1.5	1950	1810	1670	1495	1395	1255
										<b>23 / 1.6</b>	2030	1885	1740	1555	<b>1450</b>	1305
	8	TT	125 / A6							25 / 1.7	2170	2015	1860	1660	1550	1400
										28 / 1.9	2265	2105	1940	1730	1620	1455
										<b>29 / 2.0</b>	2310	2145	1980	1765	<b>1650</b>	1485
14.9-28	6	TT	125 / A6	W13	W11, W12	378	1365	4068	618	17 / 1.2	2105	1955	1805	1610	1505	1350
										19 / 1.3	2195	2040	1880	1685	1570	1410
										<b>20 / 1.4</b>	2310	2145	1980	1770	<b>1650</b>	1485
	8	TT	130 / A6							22 / 1.5	2475	2300	2120	1895	1770	1590
										23 / 1.6	2610	2420	2235	1995	1865	1675
										<b>26 / 1.8</b>	2660	2470	2280	2035	<b>1900</b>	1710
16.9-28	8	TT	135 / A6	W15L	W14L	429	1435	4276	646	20 / 1.4	2780	2580	2380	2125	1985	1790
										22 / 1.5	2905	2695	2485	2220	2070	1865
										<b>25 / 1.7</b>	3055	2835	2615	2335	<b>2180</b>	1965
	10	TT	139 / A6							25 / 1.7	3200	2970	2740	2445	2285	2060
										26 / 1.8	3270	3035	2800	2500	2335	2100
										<b>29 / 2.0</b>	3405	3160	2915	2600	<b>2430</b>	2190
	12	TT	143 A6	29 / 2.0	3585	3330	3075	2740	2560	2305						
				32 / 2.2	3700	3435	3170	2830	2645	2375						
				<b>35 / 2.4</b>	3815	3540	3270	2915	2725	2450						
14.9-30	8	TT	131 / A6	W13	W11, W12	378	1415	4217	643	22 / 1.5	2540	2360	2180	1945	1815	1635
										23 / 1.6	2675	2485	2295	2050	1910	1720
										<b>26 / 1.8</b>	2730	2535	2340	2090	<b>1950</b>	1755
	10	TT	135 / A6							29 / 2.0	2905	2695	2490	2220	2070	1870
										32 / 2.2	2995	2780	2570	2290	2140	1925
										<b>33 / 2.3</b>	3055	2835	2620	2335	<b>2180</b>	1965

\* Load capacity on recommended speed and pressure is stated with dark colour.

### DESCRIPTION

\* For load capacity on various speed ratings, and inflation figures, please consult your sales representative.

\*\* Load capacity on standard speed and weight

- Our company is entitled to make any change on any information in this catalogue, without further notice.
- This catalogue annuls all the previous catalogues
- All figures are for reference; our company is not responsible for printing errors.

## Tractor Rear • Characteristics of TA 60

Tire Size	PR	TT/TL	Load/Speed Index	Rims		Inflated Dimensions (No Load)		Inflated Dimensions (W/Load)		Inflation Pressure (psi/bar)	Load capacity per tire, kg					
				Recom (inch)	Permitted (inch)	Section Width (mm)	Outer Diameter (mm)	Dynamic Rolling Circumference (mm)	Static Loaded Radius (mm)		Speed, km/h					
											10	15	20	25	30	40
16.9-30	6	TT	130 / A6	W15L	W14L	429	1485	4425	671	15 / 1.0	2315	2150	1990	1770	1655	1490
										16 / 1.1	2420	2250	2075	1855	1730	1555
										<b>19 / 1.3</b>	2660	2470	2280	2035	<b>1900</b>	1710
	8	TT	137 / A6							20 / 1.4	2930	2725	2515	2240	2095	1885
										22 / 1.5	3060	2840	2625	2340	2185	1970
										<b>25 / 1.7</b>	3220	2990	2760	2460	<b>2300</b>	2070
	10	TT	139 / A6							29 / 2.0	3205	2970	2740	2445	2285	2060
										32 / 2.2	3340	3100	2860	2550	2380	2145
										<b>35 / 2.4</b>	3405	3160	2915	2600	<b>2430</b>	2190
	12	TT	143 / A6							29 / 2.0	3550	3300	3040	2715	2535	2285
										32 / 2.2	3665	3405	3140	2805	2615	2355
										<b>35 / 2.4</b>	3815	3545	3270	2920	<b>2725</b>	2455
14	TT	144 / A6	32 / 2.2	3650	3385	3125	2790	2605	2345							
			35 / 2.4	3765	3495	3225	2880	2690	2420							
			<b>38 / 2.6</b>	3920	3640	3360	3000	<b>2800</b>	2520							
18.4-30	6	TT	134 / A6	W16L	W15L	467	1550	4619	697	13 / 0.9	2705	2505	2315	2070	1930	1740
										15 / 1.0	2820	2620	2420	2160	2015	1815
										<b>16 / 1.1</b>	2970	2755	2545	2270	<b>2120</b>	1910
	8	TT	139 / A6							17 / 1.2	3100	2880	2660	2370	2210	1993
										19 / 1.3	3235	3000	2775	2470	2310	2080
										<b>20 / 1.4</b>	3405	3160	2920	2600	<b>2430</b>	2190
	10	TT	145 / A6							22 / 1.5	3780	3510	3240	2890	2700	2430
										23 / 1.6	3980	3695	3410	3045	2845	2560
										<b>26 / 1.8</b>	4060	3770	3480	3105	<b>2900</b>	2610
	12	TT	149 / A6							29 / 2.0	4325	4015	3705	3310	3090	2780
										32 / 2.2	4415	4100	3785	3380	3155	2840
										<b>33 / 2.3</b>	4550	4225	3900	3480	<b>3250</b>	2925
14	TT	151 / A6	33 / 2.3	4445	4130	3810	3400	3175	2860							
			36 / 2.5	4640	4310	3975	3550	3315	2980							
			<b>39 / 2.7</b>	4830	4485	4140	3695	<b>3450</b>	3105							

• Load capacity on recommended speed and pressure is stated with dark colour.



## Tractor Rear • Characteristics of TA 60

Tire Size	PR	TT/TL	Load/Speed Index	Rims		Inflated Dimensions (No Load)		Inflated Dimensions (W/Load)		Inflation Pressure (psi/bar)	Load capacity per tire, kg					
				Recom (inch)	Permitted (inch)	Section Width (mm)	Outer Diameter (mm)	Dynamic Rolling Circumference (mm)	Static Loaded Radius (mm)		Speed, km/h					
											10	15	20	25	30	40
12.4-32	8	TT	124 / A6	W11	W9, W10	315	1360	4053	626	29 / 2.0	2130	1975	1825	1630	1520	1370
										32 / 2.2	2195	2040	1885	1680	1570	1410
										<b>33 / 2.3</b>	2240	2080	1920	1715	<b>1600</b>	1440
16.9-34	8	TT	139 / A6	W15L	W14L	429	1585	4723	721	20 / 1.4	3100	2880	2655	2370	2210	1995
										22 / 1.5	3235	3005	2770	2470	2310	2080
										<b>25 / 1.7</b>	3405	3160	2915	2600	<b>2430</b>	2190
	10	TT	142 / A6							25 / 1.7	3380	3135	2990	2580	2410	2170
										26 / 1.8	3525	3275	3025	2695	2520	2270
										<b>29 / 2.0</b>	3710	3445	3180	2835	<b>2650</b>	2385
	12	TT	145 / A6							29 / 2.0	3860	3585	3305	2950	2755	2480
										32 / 2.2	3980	3695	3410	3045	2845	2560
										<b>33 / 2.3</b>	4060	3770	3480	3105	<b>2900</b>	2610
	14	TT	148 / A6							29 / 2.0	3705	3440	3175	2830	2650	2380
										33 / 2.3	4100	3810	3515	3135	2930	2640
										<b>38 / 2.6</b>	4410	4095	3780	3370	<b>3150</b>	2835
18.4-34	8	TT	141 / A6	W16L	W15L	467	1650	4917	747	17 / 1.2	3280	3050	2815	2510	2345	2110
										19 / 1.3	3425	3185	2940	2620	2450	2205
										<b>20 / 1.4</b>	3605	3350	3090	2755	<b>2575</b>	2320
	10	TT	146 / A6							22 / 1.5	3910	3630	3350	2985	2790	2510
										23 / 1.6	4115	3825	3530	3145	2940	2650
										<b>26 / 1.8</b>	4200	3900	3600	3210	<b>3000</b>	2700
	12	TT	151 / A6							29 / 2.0	4590	4260	3935	3510	3280	2950
										32 / 2.2	4735	4395	4060	3620	3380	3045
										<b>33 / 2.3</b>	4830	4485	4140	3695	<b>3450</b>	3105
	14	TT	156 / A6							29 / 2.0	4595	4265	3935	3510	3280	2955
										32 / 2.2	5210	4840	4465	3980	3720	3350
										<b>35 / 2.4</b>	5600	5200	4800	4280	<b>4000</b>	3600

• Load capacity on recommended speed and pressure is stated with dark colour.

### DESCRIPTION

\* For load capacity on various speed ratings, and inflation figures, please consult your sales representative.

\*\* Load capacity on standard speed and weight

- Our company is entitled to make any change on any information in this catalogue, without further notice.
- This catalogue annuls all the previous catalogues
- All figures are for reference; our company is not responsible for printing errors.

## Tractor Rear • Characteristics of TA 60

Tire Size	PR	TT/TL	Load/Speed Index	Rims		Inflated Dimensions (No Load)		Inflated Dimensions (W/Load)		Inflation Pressure (psi/bar)	Load capacity per tire, kg					
				Recom (inch)	Permitted (inch)	Section Width (mm)	Outer Diameter (mm)	Dynamic Rolling Circumference (mm)	Static Loaded Radius (mm)		Speed, km/h					
											10	15	20	25	30	40
12.4-36	8	TT	126 / A6	W11	W9, W10	315	1465	4366	678	29 / 2.0	2260	2100	1940	1730	1615	1455
										32 / 2.2	2335	2165	1995	1785	1670	1495
										<b>33 / 2.3</b>	2380	2210	2040	1820	<b>1700</b>	1530
13.6-36	6	TT	125 / A6	W12	W11	345	1515	4515	698	20 / 1.4	2100	1955	1800	1610	1500	1350
										22 / 1.5	2220	2060	1900	1700	1585	1430
										<b>23 / 1.6</b>	2310	2145	1980	1770	<b>1650</b>	1485
	28 / 1.9	2460	2285							2110	1880	1760	1585			
	29 / 2.0	2515	2335							2155	1920	1795	1615			
	<b>32 / 2.2</b>	2590	2405							2220	1980	<b>1850</b>	1665			
13.6-38	8	TT	131 / A6	W12	W11	345	1565	4664	723	25 / 1.7	2485	2310	2130	1905	1775	1600
										26 / 1.8	2595	2410	2225	1990	1855	1670
										<b>29 / 2.0</b>	2730	2535	2340	2090	<b>1950</b>	1755
14.00-38	8	TT	131 / A6	W12	W11	355	1570	4679	725	25 / 1.7	2485	2310	2130	1905	1775	1600
										26 / 1.8	2595	2410	2225	1990	1855	1700
										<b>29 / 2.0</b>	2730	2535	2340	2090	<b>1950</b>	1755
	29 / 2.0	2980	2770							2555	2280	2130	1915			
	32 / 2.2	3075	2860							2640	2355	2195	1980			
	<b>33 / 2.3</b>	3135	2915							2690	2400	<b>2240</b>	2015			
15.5-38	8	TT	133 / A6	W14L	-	394	1570	4679	725	22 / 1.5	2685	2495	2300	2050	1915	1725
										23 / 1.6	2830	2625	2425	2160	2020	1820
										<b>26 / 1.8</b>	2885	2680	2475	2205	<b>2060</b>	1855
	28 / 1.9	3140	2920							2695	2400	2245	2020			
	29 / 2.0	3205	2980							2750	2450	2290	2065			
	<b>32 / 2.2</b>	3305	3070							2835	2525	<b>2360</b>	2125			
	32 / 2.2	4980	3485							2990	2665	2490	2240			
	35 / 2.4	5195	3835							3115	2780	2595	2335			
	<b>38 / 2.6</b>	5300	3710							3180	2835	<b>2650</b>	2385			

• Load capacity on recommended speed and pressure is stated with dark colour.



## Tractor Rear • Characteristics of TA 60

Tire Size	PR	TT/TL	Load / Speed Index	Rims		Inflated Dimensions (No Load)		Inflated Dimensions (W/Load)		Inflation Pressure (psi/bar)	Load capacity per tire, kg					
				Recom (inch)	Permitted (inch)	Section Width (mm)	Outer Diameter (mm)	Dynamic Rolling Circumference (mm)	Static Loaded Radius (mm)		Speed, km/h					
											10	15	20	25	30	40
16.9-38	8	TT	141 / A6	W15L	W14L	429	1685	5021	771	20 / 1.4	3280	3050	2815	2510	2345	2110
										22 / 1.5	3425	3185	2940	2615	2450	2200
										<b>25 / 1.7</b>	3605	3350	3090	2755	<b>2575</b>	2320
	10	TT	144 / A6							25 / 1.7	3570	3315	3060	2730	2550	2295
										26 / 1.8	3725	3460	3195	2850	2660	2395
										<b>29 / 2.0</b>	3920	3640	3360	3000	<b>2800</b>	2520
										29 / 2.0	5640	3950	3385	3015	2820	2540
										31 / 2.1	5880	4115	3530	3145	2940	2645
										<b>33 / 2.3</b>	6000	4200	3600	3210	<b>3000</b>	2700
18.4-38	8	TT	143 / A6	W16L	W15L	467	1750	5215	797	17 / 1.2	3475	3225	2980	2660	2480	2235
										19 / 1.3	3625	3370	3110	2775	2590	2335
										<b>20 / 1.4</b>	3815	3545	3270	2920	<b>2725</b>	2455
	10	TT	147 / A6							22 / 1.5	4090	3800	3505	3125	2920	2630
										23 / 1.6	4180	3880	3580	3195	2985	2685
										<b>26 / 1.8</b>	4305	4000	3690	3290	<b>3075</b>	2770

• Load capacity on recommended speed and pressure is stated with dark colour.

### DESCRIPTION

- \* For load capacity on various speed ratings, and inflation figures, please consult your sales representative.
- \*\* Load capacity on standard speed and weight

- Our company is entitled to make any change on any information in this catalogue, without further notice.
- This catalogue annuls all the previous catalogues
- All figures are for reference; our company is not responsible for printing errors.

# TA 300

Tractor  
Rear

## PERFORMANCE INFORMATION

R1 farm rear tire with high resistance/traction and deep tread design for tough operating conditions



## FEATURES

### Long service life / Durability

- Strong nylon carcass structure provides optimum durability
- Tread compound specially developed for stony/tough terrains provides high resistance against wear and cuts
- Tread profile with extra wide tread base provides perfect resistance to tread base fatigue

### Ease of use

- Wide and reinforced body provides easy grip, high traction and reduced slipping
- Special tread design for tough terrains provides superior performance

## SIZES

9.5-24 • 11.2-24 • 12.4-24 • 13.6-24 • 14.9-24 • 12.4-28 • 13.6-28 • 14.9-28  
14.9-30 • 16.9-30 • 18.4-30 • 16.9-34 • 18.4-34 • 12.4-36 • 13.6-36 • 16.9-38



## Tractor Rear • Characteristics of TA 300

Tire Size	PR	TT/TL	Load/Speed Index	Rims		Inflated Dimensions (No Load)		Inflated Dimensions (W/Load)		Inflation Pressure (psi/bar)	Load capacity per tire, kg					
				Recom (inch)	Permitted (inch)	Section Width (mm)	Outer Diameter (mm)	Dynamic Rolling Circumference (mm)	Static Loaded Radius (mm)		Speed, km/h					
											10	15	20	25	30	40
9.5-24	8	TT	112 / A6	W8	W7	241	1050	3180	490	33 / 2.3	1430	1325	1225	1095	1020	920
										36 / 2.5	1495	1385	1280	1140	1065	960
										<b>41 / 2.8</b>	1570	1455	1345	1200	<b>1120</b>	1010
11.2-24	8	TT	116 / A6	W10	W9	284	1105	3310	505	29 / 2.0	1630	1515	1395	1250	1165	1040
										32 / 2.2	1680	1560	1440	1290	1200	1080
										<b>35 / 2.4</b>	1750	1625	1500	1340	<b>1250</b>	1125
12.4-24	8	TT	120 / A6	W11	W9, W10	315	1160	3465	530	29 / 2.0	1865	1730	1600	1425	1330	1200
										32 / 2.2	1920	1790	1650	1470	1375	1235
										<b>33 / 2.3</b>	1960	1820	1680	1500	<b>1400</b>	1260
	10	TT	124 / A6	W11	W9, W10	315	1160	3465	520	29 / 2.0	2976	2083	1786	1592	1488	1339
										32 / 2.2	3088	2162	1853	1652	1544	1390
										<b>33 / 2.3</b>	3200	2240	1920	1712	<b>1600</b>	1440
13.6-24	8	TT	123 / A6	DW12	DW11	345	1260	3625	541	20 / 1.4	1975	1835	1695	1510	1410	1270
										25 / 1.7	2085	1935	1790	1595	1490	1340
										<b>29 / 2.0</b>	2170	2015	1860	1660	<b>1550</b>	1395
14.9-24	8	TT	128 / A6	W13	W11, W12	378	1265	3770	565	22 / 1.5	2395	2220	2055	1835	1710	1540
										23 / 1.6	2445	2270	2095	1875	1745	1570
										<b>26 / 1.8</b>	2520	2340	2160	1930	<b>1800</b>	1620
12.4-28	8	TT	122 / A6	W11	W9, W10	315	1260	3770	582	29 / 2.0	1995	1855	1710	1525	1425	1285
										32 / 2.2	2060	1910	1765	1575	1470	1325
										<b>33 / 2.3</b>	2100	1950	1800	1605	<b>1500</b>	1350
13.6-28	8	TT	125 / A6	W12	W11	345	1310	3905	602	25 / 1.7	2170	2015	1860	1665	1550	1400
										28 / 1.9	2265	2105	1940	1735	1620	1455
										<b>29 / 2.0</b>	2310	2145	1980	1770	<b>1650</b>	1485

• Load capacity on recommended speed and pressure is stated with dark colour.

### DESCRIPTION

\* For load capacity on various speed ratings, and inflation figures, please consult your sales representative.

\*\* Load capacity on standard speed and weight

- Our company is entitled to make any change on any information in this catalogue, without further notice.
- This catalogue annuls all the previous catalogues
- All figures are for reference; our company is not responsible for printing errors.

## Tractor Rear • Characteristics of TA 300

Tire Size	PR	TT/TL	Load/Speed Index	Rims		Inflated Dimensions (No Load)		Inflated Dimensions (W/Load)		Inflation Pressure (psi/bar)	Load capacity per tire, kg					
				Recom (inch)	Permitted (inch)	Section Width (mm)	Outer Diameter (mm)	Dynamic Rolling Circumference (mm)	Static Loaded Radius (mm)		Speed, km/h					
											10	15	20	25	30	40
14.9-28	8	TT	130 / A6	W13	W11, W12	378	1365	4070	622	22 / 1.5	2530	2345	2170	1930	1805	1625
										23 / 1.6	2580	2395	2215	1975	1845	1660
										<b>26 / 1.8</b>	2660	2470	2280	2035	<b>1900</b>	1710
14.9-30	8	TT	131 / A6	W13	W11, W12	378	1415	4230	660	22 / 1.5	2595	2410	2225	1990	1855	1670
										23 / 1.6	2650	2465	2270	2030	1895	1705
										<b>26 / 1.8</b>	2730	2535	2340	2090	<b>1950</b>	1755
16.9-30	8	TT	137 / A6	W15L	W14L	429	1485	4430	668	22 / 1.5	3060	2840	2625	2340	2185	1970
										23 / 1.6	3125	2900	2680	2390	2230	2010
	<b>25 / 1.7</b>	3220	2990							2760	2460	<b>2300</b>	2070			
	26 / 1.8	3200	2970							2740	2445	2285	2060			
	30 / 2.1	3270	3035							2800	2500	2335	2105			
10	TT	139 / A6	<b>35 / 2.4</b>	3405	3160	2915	2600	<b>2430</b>	2190							
18.4-30	8	TT	139 / A6	W16L	W15L	467	1550	4620	700	17 / 1.2	3100	2875	2660	2370	2210	1995
										19 / 1.3	3235	3005	2775	2470	2310	2080
										<b>20 / 1.4</b>	3405	3160	2920	2600	<b>2430</b>	2190
	22 / 1.5	3860	3580							3310	2950	2755	2480			
	23 / 1.6	3940	3660							3380	3015	2815	2535			
	<b>26 / 1.8</b>	4060	3770							3480	3105	<b>2900</b>	2610			
	12	TT	149 / A6	29 / 2.0	6045	4232	3627	3234	3023	2720						
				30 / 2.1	6162	4313	3697	3297	3081	2773						
				<b>33 / 2.3</b>	6500	4550	3900	3250	<b>3250</b>	2925						
	14	TT	151 / A6	22 / 3,3	6490	4540	3890	3470	3245	2920						
				24 / 3,5	6690	4685	4015	3580	3345	3010						
				<b>26 / 3,8</b>	6900	4830	4140	3690	<b>3450</b>	3105						
16.9-34	8	TT	139 / A6	W15L	W14L	429	1585	4715	725	22 / 1.5	3235	3005	2775	2470	2310	2080
										23 / 1.6	3305	3070	2835	2525	2360	2120
										<b>25 / 1.7</b>	3405	3160	2920	2600	<b>2430</b>	2190
18.4-34	8	TT	141 / A6	W16L	W15L	467	1650	4915	750	17 / 1.2	3280	3050	2815	2510	2345	2110
										19 / 1.3	3425	3185	2940	2620	2450	2205
										<b>20 / 1.4</b>	3605	3350	3090	2755	<b>2575</b>	2320

\* Load capacity on recommended speed and pressure is stated with dark colour.



## Tractor Rear • Characteristics of TA 300

Tire Size	PR	TT/TL	Load/Speed Index	Rims		Inflated Dimensions (No Load)		Inflated Dimensions (W/Load)		Inflation Pressure (psi/bar)	Load capacity per tire, kg					
				Recom (inch)	Permitted (inch)	Section Width (mm)	Outer Diameter (mm)	Dynamic Rolling Circumference (mm)	Static Loaded Radius (mm)		Speed, km/h					
											10	15	20	25	30	40
12.4-36	8	TT	126 / A6	W11	W9, W10	315	1465	4365	682	29 / 2.0	2260	2100	1940	1730	1615	1455
										32 / 2.2	2335	2170	2000	1785	1670	1500
										<b>33 / 2.3</b>	2380	2210	2040	1820	<b>1700</b>	1530
13.6-36	8	TT	129 / A6	W12	W11	345	1515	4520	692	28 / 1.9	2460	2290	2110	1880	1760	1585
										29 / 2.0	2515	2335	2155	1920	1795	1615
										<b>32 / 2.2</b>	2590	2405	2220	1980	<b>1850</b>	1665
16.9-38	8	TT	141 / A6	W15L	W14L	429	1685	4950	767	22 / 1.5	3425	3185	2940	2620	2450	2205
										23 / 1.6	3500	3250	2300	2675	2500	2250
										<b>25 / 1.7</b>	3605	3350	3090	2755	<b>2575</b>	2320

• Load capacity on recommended speed and pressure is stated with dark colour.



### DESCRIPTION

\* For load capacity on various speed ratings, and inflation figures, please consult your sales representative.

\*\* Load capacity on standard speed and weight

- Our company is entitled to make any change on any information in this catalogue, without further notice.
- This catalogue annuls all the previous catalogues
- All figures are for reference; our company is not responsible for printing errors.

# TA 330

Tractor  
Rear

## PERFORMANCE INFORMATION

R1 farm rear tire with high resistance/traction and deep tread design for tough operating conditions



## FEATURES

### Long service life / Durability

- Strong nylon carcass structure provides optimum durability
- Tread compound specially developed for stony/tough terrains provides high resistance against wear and cuts
- Tread profile with extra wide tread base provides perfect resistance to tread base fatigue

### Ease of use

- Wide and reinforced body provides easy grip, high traction and reduced slipping
- Special tread design for tough terrains provides superior performance

## SIZES 30.5L-32



## Tractor Rear • Characteristics of TA 330

Tire Size	PR	TT/TL	Load/Speed Index	Rims		Inflated Dimensions (No Load)		Inflated Dimensions (W/Load)		Inflation Pressure (psi/bar)	Load capacity per tire, kg					
				Recom (inch)	Permitted (inch)	Section Width (mm)	Outer Diameter (mm)	Dynamic Rolling Circumference (mm)	Static Loaded Radius (mm)		Speed, km/h					
											10	15	20	25	30	40
30.5L32	12	TL	158 / A8	DW27B	DHB27, DH27B, DH27H	770	1840	5485	828	20 / 1.4	-	-	-	-	4750	4250

- Load capacity on recommended speed and pressure is stated with dark colour.
- 30.5 L32 18PR is also available for harvesters.

### DESCRIPTION

- \* For load capacity on various speed ratings, and inflation figures, please consult your sales representative.
- \*\* Load capacity on standard speed and weight

- Our company is entitled to make any change on any information in this catalogue, without further notice.
- This catalogue annuls all the previous catalogues
- All figures are for reference; our company is not responsible for printing errors.

Tractor/Harvester  
Row Crop

RADIAL

TA 110

TA 140

TA 130 Harvester  
Tractor

TA 120 Row Crop



TA 110

TA 140

TA 130 Harvester-Tractor

TA 120 Row Crop



Row Crop



# TA 110<sup>/65</sup>

Tractor  
Radial

## PERFORMANCE INFORMATION

General purpose R1W farm front and rear tire with standard profile and tread design for high traction tractors



## FEATURES

### Long service life / Durability

- Strong carcass and impact ply
- Special tread compound provides high resistance against wear and cuts
- Tread profile provides high resistance against tread base fatigue and the tire maintains its traction performance even at its half-life

### Ease of use

- Special tread geometry provides self cleaning
- Strong and flexible sidewall
- Perfect grip/high traction with wide footprint

### Low soil compaction

#### / Reduced slip

- Special tread structure provides high traction and less sinking at soft surfaces
- Wide footprint provides lower soil compaction
- Ensures a balanced steering by reduced slip at all surfaces

**SIZES** 420/65 R24 • 480/65 R24 • 540/65 R24 • 440/65 R28 • 480/65 R28 • 540/65 R28  
540/65 R30 • 540/65 R34 • 600/65 R34 • 540/65 R38 • 600/65 R38 • 650/65 R38



# Tractor Radial • Characteristics of TA 110 /65

Tire Size	TT/TL	Load/Speed Index	Rims		Inflated Dimensions (No Load)		Inflated Dimensions (W/Load)		Inflation Pressure (psi/bar)	Load capacity per tire, kg				
			Recom (inch)	Permitted (inch)	Section Width (mm)	Outer Diameter (mm)	Dynamic Rolling Circumference (mm)	Static Loaded Radius (mm)		Speed, km/h				
										20	30	40	50	65
420/65 R24	TL	126 D/126 B	W13	W11, W12	418	1156	3468	523,8	20 / 1,4	1905	1780	1695	1625	1545
									22 / 1,5	1985	1855	1770	1670	1615
									23 / 1,6	2090	1955	1860	1785	1700
440/65 R24	TL	128 D/131 A8	W14	W13, W15	440	1184	3552	538	9 / 0.6	1340	1160	1105	1060	1010
									12 / 0.8	1575	1365	1300	1245	1190
									15 / 1.0	1815	1575	1495	1435	1365
									20 / 1,4	2050	1780	1695	1625	1545
									22 / 1,5	2220	1925	1830	1760	1675
									<b>23 / 1,6</b>	<b>2390</b>	<b>2070</b>	<b>1950</b>	<b>1890</b>	<b>1800</b>
									26 / 1.8	2555	-	-	-	-
28 / 1.9	2630	-	-	-	-									
480/65 R24	TL	133 D/136 A8	W15	W14	475	1236	3716	564	9 / 0.6	1580	1345	1285	1225	1175
									12 / 0.8	1840	1560	1490	1425	1355
									15 / 1.0	2110	1785	1700	1625	1545
									17 / 1.2	2340	2005	1910	1835	1750
									20 / 1.4	2535	2180	2080	1990	1900
									<b>23 / 1.6</b>	<b>2730</b>	<b>2360</b>	<b>2240</b>	<b>2160</b>	<b>2060</b>
									26 / 1.8	2880	-	-	-	-
28 / 1.9	2995	-	-	-	-									
540/65 R24	TL	140 D/143 A8	W16	W18	530	1310	3930	594	9 / 0.6	1990	1600	1530	1460	1400
									12 / 0.8	2225	1870	1780	1705	1625
									15 / 1.0	2500	2155	2050	1965	1875
									17 / 1.2	2760	2425	2425	2215	2110
									20 / 1.4	3015	2645	2520	2420	2300
									<b>23 / 1.6</b>	<b>3255</b>	<b>2875</b>	<b>2725</b>	<b>2625</b>	<b>2500</b>
									26 / 1.8	3375	-	-	-	-
28 / 1.9	3490	-	-	-	-									
440/65 R28	TL	131 D/134 A8	W14	W13- W15	440	1284	3866	584	9 / 0.6	1560	1245	1185	1130	1080
									12 / 0.8	1730	1455	1390	1330	1265
									15 / 1.0	1960	1680	1600	1535	1460
									17 / 1.2	2170	1900	1800	1730	1650
									20 / 1.4	2345	2060	1965	1885	1795
									<b>23 / 1.6</b>	<b>2535</b>	<b>2240</b>	<b>2120</b>	<b>2050</b>	<b>1950</b>
									26 / 1.8	2680	-	-	-	-
28 / 1.9	2765	-	-	-	-									

• Load capacity on recommended speed and pressure is stated with dark colour.

## DESCRIPTION

\* For load capacity on various speed ratings, and inflation figures, please consult your sales representative.

\*\* Load capacity on standard speed and weight

• Our company is entitled to make any change on any information in this catalogue, without further notice.

• This catalogue annuls all the previous catalogues

• All figures are for reference; our company is not responsible for printing errors.

## Tractor Radial • Characteristics of TA 110 /65

Tire Size	TT/TL	Load/Speed Index	Rims		Inflated Dimensions (No Load)		Inflated Dimensions (W/Load)		Inflation Pressure (psi/bar)	Load capacity per tire, kg				
			Recom (inch)	Permitted (inch)	Section Width (mm)	Outer Diameter (mm)	Dynamic Rolling Circumference (mm)	Static Loaded Radius (mm)		Speed, km/h				
										20	30	40	50	65
480/65 R28	TL	136 D/139 A8	W15L	W14L	475	1337	4035	605	9 / 0.6	1675	1420	1355	1295	1235
									12 / 0.8	2000	1680	1595	1525	1455
									15 / 1.0	2230	1935	1830	1765	1680
									17 / 1.2	2480	2180	2075	1990	1900
									20 / 1.4	2690	2370	2245	2160	2060
									<b>23 / 1.6</b>	2915	2575	2430	2350	<b>2240</b>
									26 / 1.8	3080	-	-	-	-
28 / 1.9	3185	-	-	-	-									
540/65 R28	TL	149 D/152 A8	W16L	W18L	530	1412	4248	637	9 / 0.6	1840	1785	1680	1600	1530
									12 / 0.8	2155	2090	1980	1905	1820
									15 / 1.0	2420	2355	2235	2140	2045
									17 / 1.2	2670	2610	2475	2380	2275
									20 / 1.4	2940	2870	2730	2620	2500
									23 / 1.6	3180	3100	2940	2820	2695
									29 / 2.0	3530	3435	3260	3125	2990
<b>35 / 2.4</b>	3845	3735	3550	3400	<b>3250</b>									
540/65 R30	TL	150 D/153 A8	W16L	W18L	530	1461	4390	664	9 / 0.6	2070	1845	1760	1685	1600
									12 / 0.8	2440	2155	2055	1965	1875
									15 / 1.0	2740	2425	2310	2210	2110
									17 / 1.2	3045	2695	2565	2460	2345
									20 / 1.4	3350	2965	2825	2705	2575
									23 / 1.6	3615	3195	3045	2915	2780
									29 / 2.0	3960	3500	3340	3195	3050
<b>35 / 2.4</b>	4355	3850	3650	3515	<b>3350</b>									
540/65 R34	TL	145 D/148 A8	W16L	W18L	530	1568	4698	711	9 / 0.6	2330	1865	1800	1705	1620
									12 / 0.8	2635	2210	2105	2015	1930
									15 / 1.0	2940	2545	2400	2320	2205
									17 / 1.2	3220	2850	2730	2620	2480
									20 / 1.4	3520	3095	2945	2830	2685
									<b>23 / 1.6</b>	3790	3335	3150	3045	<b>2900</b>
									26 / 1.8	3870	-	-	-	-
28 / 1.9	3990	-	-	-	-									

• Load capacity on recommended speed and pressure is stated with dark colour.



# Tractor Radial • Characteristics of TA 110 /65

Tire Size	TT/TL	Load/Speed Index	Rims		Inflated Dimensions (No Load)		Inflated Dimensions (W/Load)		Inflation Pressure (psi/bar)	Load capacity per tire, kg				
			Recom (inch)	Permitted (inch)	Section Width (mm)	Outer Diameter (mm)	Dynamic Rolling Circumference (mm)	Static Loaded Radius (mm)		Speed, km/h				
										20	30	40	50	65
600/65 R34	TL	151 D/154 A8	DW20B	W18L	586	1646	4897	741	9 / 0.6	2655	2220	2125	2035	1935
									12 / 0.8	3100	2590	2475	2380	2245
									15 / 1.0	3470	2970	2830	2715	2580
									17 / 1.2	3855	3330	3165	3050	2880
									20 / 1.4	4175	3640	3465	3330	3170
									<b>23 / 1.6</b>	4500	3960	3750	3620	<b>3450</b>
									26 / 1.8	4770	-	-	-	-
									28 / 1.9	4930	-	-	-	-
540/65 R38	TL	147 D/150 A8	W16L	W18L	530	1672	4966	749	9 / 0.6	2460	1990	1900	1810	1725
									12 / 0.8	2785	2300	2205	2115	2000
									15 / 1.0	3090	2650	2500	2400	2290
									17 / 1.2	3420	2940	2815	2700	2560
									20 / 1.4	3710	3245	3080	2955	2820
									<b>23 / 1.6</b>	4030	3530	3350	3230	<b>3075</b>
									26 / 1.8	4250	-	-	-	-
									28 / 1.9	4410	-	-	-	-
600/65 R38	TL	159 D/162 A8	DW20B	W18L	586	1747	5229	786	9 / 0.6	2680	2405	2285	2195	2100
									12 / 0.8	3135	2810	2665	2560	2450
									15 / 1.0	3525	3160	2995	2885	2755
									17 / 1.2	3920	3515	3330	3205	3060
									20 / 1.4	4310	3865	3665	3525	3370
									23 / 1.6	4705	4215	400	3845	3675
									29 / 2.0	5150	4620	4380	4210	4025
									<b>35 / 2.4</b>	5600	5020	4750	4580	<b>4375</b>
650/65 R38	TL	163 D/166 A8	DW20B	-	652	1841	5510	825	9 / 0.6	3090	2700	2565	2470	2350
									12 / 0.8	3580	3135	2980	2865	2730
									15 / 1.0	4030	3525	3350	3220	3070
									17 / 1.2	4480	3920	3720	3580	3410
									20 / 1.4	4930	4310	4095	3940	3750
									23 / 1.6	5310	4645	4415	4250	4045
									29 / 2.0	5890	5150	4890	4710	4485
									<b>35 / 2.4</b>	6400	5600	5300	5120	<b>4875</b>

• Load capacity on recommended speed and pressure is stated with dark colour.

## DESCRIPTION

\* For load capacity on various speed ratings, and inflation figures, please consult your sales representative.

\*\* Load capacity on standard speed and weight

- Our company is entitled to make any change on any information in this catalogue, without further notice.
- This catalogue annuls all the previous catalogues
- All figures are for reference; our company is not responsible for printing errors.

# TA 110<sup>/70</sup>

Tractor Radial

## PERFORMANCE INFORMATION

General purpose R1W farm front and rear tire with standard profile and tread design for high traction tractors



## FEATURES

### Long service life / Durability

- Strong carcass and impact ply
- Special tread compound provides high resistance against wear and cuts
- Tread profile provides high resistance against tread base fatigue and the tire maintains its traction performance even at its half-life

### Ease of use

- Special tread geometry provides self cleaning
- Strong and flexible sidewall
- Perfect grip/high traction with wide footprint

### Low soil compaction / Reduced slip

- Special tread structure provides high traction and less sinking at soft surfaces
- Wide footprint provides lower soil compaction
- Ensures a balanced steering by reduced slip at all surfaces

## SIZES

200/70 R16 • 240/70 R16 • 260/70 R16 • 280/70 R16 • 280/70 R18 • 260/70 R20 • 280/70 R20 • 300/70 R20 • 320/70 R20  
360/70 R20 • 380/70 R20 • 320/70 R24 • 360/70 R24 • 380/70 R24 • 420/70 R24 • 480/70 R24 • 480/70 R26 • 320/70 R28  
360/70 R28 • 380/70 R28 • 420/70 R28 • 420/70 R30 • 480/70 R28 • 480/70 R30 • 520/70 R30 • 480/70 R34 • 520/70 R34  
480/70 R38 • 520/70 R38 • 580/70 R38 • 580/70 R42



## Tractor Radial • Characteristics of TA 110 /70

Tire Size	TT/TL	Load/Speed Index	Rims		Inflated Dimensions (No Load)		Inflated Dimensions (W/Load)		Inflation Pressure (psi/bar)	Load capacity per tire, kg			
			Recom (inch)	Permitted (inch)	Section Width (mm)	Outer Diameter (mm)	Dynamic Rolling Circumference (mm)	Static Loaded Radius (mm)		Speed, km/h			
										10	30	40	50
200/70 R16	TL	94 A8 / 94 B	W6	W7	197	691	2050	312	9/0.6	410	360	-	-
									12/0.8	520	395	370	-
									15/1.0	565	435	405	405
									17/1.2	610	475	445	445
									20/1.4	655	515	480	480
									23/1.6	700	550	515	515
									26/1.8	745	595	555	555
									28/1.9	745	595	555	555
									29/2.0	790	635	595	595
									32 / 2.2	840	675	630	630
								<b>35 / 2.4</b>	890	715	<b>670</b>	670	
240/70 R16	TL	104 A8 / 101 B	W8	W8L-W9	244	742	2219	334	9 / 0.6	-	450	-	-
									12 / 0.8	650	500	470	-
									15 / 1.0	720	550	530	350
									17 / 1.2	780	610	570	400
									20 / 1.4	845	660	600	480
									23 / 1.6	900	690	640	540
									26 / 1.8	945	740	680	600
									28 / 1.9	980	775	720	680
									29 / 2.0	1030	820	775	735
									32 / 2.2	1100	900	830	780
								<b>35 / 2.4</b>	1160	960	<b>900</b>	825	
260/70 R16	TL	109 A8 / 106 B	W8	W8L-W9	258	770	2302	345	9 / 0.6	600	535	-	-
									12 / 0.8	750	575	530	-
									15 / 1.0	820	630	590	500
									17 / 1.2	890	685	640	570
									20 / 1.4	960	750	700	630
									23 / 1.6	1010	800	740	680
									26 / 1.8	1050	840	790	730
									28 / 1.9	1090	885	820	780
									29 / 2.0	1130	955	900	840
									32 / 2.2	1240	1035	965	900
								<b>35 / 2.4</b>	1320	1090	<b>1030</b>	950	

• Load capacity on recommended speed and pressure is stated with dark colour.

### DESCRIPTION

\* For load capacity on various speed ratings, and inflation figures, please consult your sales representative.

\*\* Load capacity on standard speed and weight

- Our company is entitled to make any change on any information in this catalogue, without further notice.
- This catalogue annuls all the previous catalogues
- All figures are for reference; our company is not responsible for printing errors.

## Tractor Radial • Characteristics of TA 110<sup>/70</sup>

Tire Size	TT/TL	Load/Speed Index	Rims		Inflated Dimensions (No Load)		Inflated Dimensions (W/Load)		Inflation Pressure (psi/bar)	Load capacity per tire, kg			
			Recom (inch)	Permitted (inch)	Section Width (mm)	Outer Diameter (mm)	Dynamic Rolling Circumference (mm)	Static Loaded Radius (mm)		Speed, km/h			
										10	30	40	50
280/70 R16	TL	112 A8 / 112 B	W9	W8-W8L W10	282	805	2390	358	9 / 0.6	660	580	-	-
									12 / 0.8	850	650	600	-
									15 / 1.0	920	710	670	670
									17 / 1.2	1000	760	720	720
									20 / 1.4	1050	840	780	780
									23 / 1.6	1130	900	840	840
									26 / 1.8	1170	940	880	880
									28 / 1.9	1210	980	920	920
									29 / 2.0	1300	1040	960	960
									32 / 2.2	1370	1110	1050	1050
								<b>35 / 2.4</b>	1460	1190	<b>1120</b>	1120	
280/70 R18	TL	114 A8 / 114 B	W9	W8-W10	282	846	2540	384	9 / 0.6	700	600	-	-
									12 / 0.8	880	660	620	-
									15 / 1.0	960	740	700	700
									17 / 1.2	1040	810	750	750
									20 / 1.4	1110	880	820	820
									23 / 1.6	1210	950	890	890
									26 / 1.8	1260	1000	940	940
									28 / 1.9	1300	1030	970	970
									29 / 2.0	1370	1110	1030	1030
									32 / 2.2	1460	1170	1090	1090
								<b>35 / 2.4</b>	1540	1250	<b>1180</b>	1180	
260/70 R20	TL	113 A8 / 113 B	W8	W9-9	258	880	2635	397	9 / 0.6	700	610	-	-
									12 / 0.8	930	725	660	-
									15 / 1.0	1010	780	730	730
									17 / 1.2	1090	860	810	810
									20 / 1.4	1190	920	860	860
									23 / 1.6	1240	980	920	920
									26 / 1.8	1270	1010	950	950
									28 / 1.9	1340	1050	980	980
									29 / 2.0	1430	1125	1040	1040
									32 / 2.2	1510	1160	1080	1080
								<b>35 / 2.4</b>	1550	1230	<b>1150</b>	1150	

• Load capacity on recommended speed and pressure is stated with dark colour.



# Tractor Radial • Characteristics of TA 110/70

Tire Size	TT/TL	Load/Speed Index	Rims		Inflated Dimensions (No Load)		Inflated Dimensions (W/Load)		Inflation Pressure (psi/bar)	Load capacity per tire, kg			
			Recom (inch)	Permitted (inch)	Section Width (mm)	Outer Diameter (mm)	Dynamic Rolling Circumference (mm)	Static Loaded Radius (mm)		Speed, km/h			
										10	30	40	50
280/70 R20	TL	116 A8 / 116 B	W9	W10	282	912	2736	416	9 / 0.6	-	-	-	-
									12 / 0.8	930	750	710	-
									15 / 1.0	1080	840	780	780
									17 / 1.2	1140	900	840	840
									20 / 1.4	1270	1000	915	915
									23 / 1.6	1320	1040	970	970
									26 / 1.8	1400	1100	1030	1030
									28 / 1.9	1480	1160	1075	1075
									29 / 2.0	1510	1200	1120	1120
									32 / 2.2	1580	1260	1180	1180
<b>35 / 2.4</b>	1640	1330	<b>1250</b>	1250									
300/70 R20	TL	110 A8 / 110 B	W9	W10	290	954	2811	435	9 / 0.6	820	730	-	-
									12 / 0.8	1040	800	750	-
									15 / 1.0	1155	880	830	830
									17 / 1.2	1240	970	900	900
									20 / 1.4	1300	1040	970	970
									<b>23 / 1.6</b>	1420	1120	<b>1060</b>	1060
									26 / 1.8	1490	-	-	-
									28 / 1.9	1555	-	-	-
320/70 R20	TL	113 A8 / 113 B	W10	W9-W11	319	983	2919	442	9 / 0.6	790	790	735	735
									12 / 0.8	850	850	825	825
									15 / 1.0	940	940	890	890
									17 / 1.2	1020	1020	935	935
									20 / 1.4	1110	1110	1050	1050
									<b>23 / 1.6</b>	1230	1230	<b>1150</b>	1150
									26 / 1.8	1280	-	-	-
									28 / 1.9	1340	-	-	-

• Load capacity on recommended speed and pressure is stated with dark colour.

## DESCRIPTION

\* For load capacity on various speed ratings, and inflation figures, please consult your sales representative.

\*\* Load capacity on standard speed and weight

- Our company is entitled to make any change on any information in this catalogue, without further notice.
- This catalogue annuls all the previous catalogues
- All figures are for reference; our company is not responsible for printing errors.

## Tractor Radial • Characteristics of TA 110<sup>/70</sup>

Tire Size	TT/TL	Load/Speed Index	Rims		Inflated Dimensions (No Load)		Inflated Dimensions (W/Load)		Inflation Pressure (psi/bar)	Load capacity per tire, kg			
			Recom (inch)	Permitted (inch)	Section Width (mm)	Outer Diameter (mm)	Dynamic Rolling Circumference (mm)	Static Loaded Radius (mm)		Speed, km/h			
										10	30	40	50
360/70 R20	TL	120 A8 / 117 B	W11	W10-W12	357	1042	3116	463	9 / 0.6	960	960	900	835
									12 / 0.8	1050	1050	950	880
									15 / 1.0	1170	1170	1060	970
									17 / 1.2	1275	1275	1150	1060
									20 / 1.4	1370	1370	1270	1155
									<b>23 / 1.6</b>	1490	1490	<b>1400</b>	1285
									26 / 1.8	1560	-	-	-
									28 / 1.9	1625	-	-	-
380/70 R20	TL	132 A8 / 132 B	W12	W11-W13	380	1082	3246	484	29 / 2.0	-	1990	1860	1860
									32 / 2.2	-	2060	1930	1930
									<b>35 / 2.4</b>	-	2140	<b>2000</b>	2000
320/70 R24	TL	116 A8 / 113 B	W10	W9-W11	319	1094	3271	494	9 / 0.6	1040	840	-	-
									12 / 0.8	1200	930	880	800
									15 / 1.0	1295	1030	935	875
									17 / 1.2	1400	1140	1040	980
									20 / 1.4	1540	1230	1130	1080
									<b>23 / 1.6</b>	1680	1330	<b>1250</b>	1150
									26 / 1.8	1750	-	-	-
									28 / 1.9	1815	-	-	-
360/70 R24	TL	122 A8 / 119 B	W11	W10-W12	357	1152	3433	517	9 / 0.6	1110	930	790	715
									12 / 0.8	1250	1090	930	835
									15 / 1.0	1500	1160	1050	945
									17 / 1.2	1640	1300	1200	1080
									20 / 1.4	1790	1450	1330	1200
									<b>23 / 1.6</b>	2030	1605	<b>1500</b>	1360
									26 / 1.8	2170	-	-	-
									28 / 1.9	2270	-	-	-
380/70 R24	TL	125 A8 / 125 B	W12	W11-W13	380	1190	3562	538	9 / 0.6	1200	955	870	800
									12 / 0.8	1400	1075	1040	930
									15 / 1.0	1590	1235	1195	1070
									17 / 1.2	1790	1400	1330	1190
									20 / 1.4	2010	1580	1485	1320
									<b>23 / 1.6</b>	2200	1710	<b>1650</b>	1500
									26 / 1.8	2330	-	-	-
									28 / 1.9	2410	-	-	-

• Load capacity on recommended speed and pressure is stated with dark colour.



# Tractor Radial • Characteristics of TA 110/70

Tire Size	TT/TL	Load/Speed Index	Rims		Inflated Dimensions (No Load)		Inflated Dimensions (W/Load)		Inflation Pressure (psi/bar)	Load capacity per tire, kg			
			Recom (inch)	Permitted (inch)	Section Width (mm)	Outer Diameter (mm)	Dynamic Rolling Circumference (mm)	Static Loaded Radius (mm)		Speed, km/h			
										10	30	40	50
420/70 R24	TL	130 A8 / 127 B	W13	W12-W14L	418	1248	3732	554	9 / 0.6	1390	1100	1030	945
									12 / 0.8	1600	1300	1200	1080
									15 / 1.0	1840	1450	1370	1270
									17 / 1.2	2075	1630	1530	1400
									20 / 1.4	2300	1845	1720	1540
									<b>23 / 1.6</b>	2480	2030	<b>1900</b>	1750
									26 / 1.8	2620	-	-	-
28 / 1.9	2750	-	-	-									
480/70 R24	TL	138 A8 / 135 B	W15L	W14L-W16L	478	1295	3885	576	9 / 0.6	1730	1370	1300	1100
									12 / 0.8	2000	1580	1500	1290
									15 / 1.0	2280	1820	1780	1550
									17 / 1.2	2565	2040	1940	1760
									20 / 1.4	2860	2290	2150	1970
									<b>23 / 1.6</b>	3180	2515	<b>2360</b>	2180
									26 / 1.8	3300	-	-	-
28 / 1.9	3395	-	-	-									
480/70 R26	TL	139 A8 / 136 B	W15L	W14L-W16L	478	1365	4080	619	9 / 0.6	1980	1515	1300	1220
									12 / 0.8	2280	1715	1560	1425
									15 / 1.0	2480	1895	1775	1615
									17 / 1.2	2780	2130	1980	1810
									20 / 1.4	3030	2340	2200	2000
									<b>23 / 1.6</b>	3280	2580	<b>2430</b>	2240
									26 / 1.8	3500	-	-	-
28 / 1.9	3700	-	-	-									
320/70 R28	TL	119 A8 / 116 B	W10	W9-W11	319	1189	3555	547	9 / 0.6	1190	940	880	800
									12 / 0.8	1300	1035	970	880
									15 / 1.0	1430	1135	1000	960
									17 / 1.2	1570	1210	1135	1050
									20 / 1.4	1700	1340	1240	1135
									<b>23 / 1.6</b>	1800	1450	<b>1360</b>	1250
									26 / 1.8	1910	-	-	-
28 / 1.9	2030	-	-	-									

• Load capacity on recommended speed and pressure is stated with dark colour.

## DESCRIPTION

\* For load capacity on various speed ratings, and inflation figures, please consult your sales representative.

\*\* Load capacity on standard speed and weight

- Our company is entitled to make any change on any information in this catalogue, without further notice.
- This catalogue annuls all the previous catalogues
- All figures are for reference; our company is not responsible for printing errors.



## Tractor Radial • Characteristics of TA 110<sup>/70</sup>

Tire Size	TT/TL	Load/Speed Index	Rims		Inflated Dimensions (No Load)		Inflated Dimensions (W/Load)		Inflation Pressure (psi/bar)	Load capacity per tire, kg			
			Recom (inch)	Permitted (inch)	Section Width (mm)	Outer Diameter (mm)	Dynamic Rolling Circumference (mm)	Static Loaded Radius (mm)		Speed, km/h			
										10	30	40	50
360/70 R28	TL	125 A8 / 122 B	W11	W10-W12	351	1248	3780	570	9 / 0.6	1200	940	880	800
									12 / 0.8	1420	1120	1040	960
									15 / 1.0	1590	1260	1190	1080
									17 / 1.2	1810	1430	1340	1230
									20 / 1.4	2010	1590	1500	1340
									<b>23 / 1.6</b>	2240	1760	<b>1650</b>	1500
									26 / 1.8	2360	-	-	-
									28 / 1.9	2440	-	-	-
380/70 R28	TL	127 A8 / 127 B	W12	W11-W13	377	1290	3888	586	9 / 0.6	1250	1015	940	860
									12 / 0.8	1480	1180	1160	1000
									15 / 1.0	1715	1350	1280	1150
									17 / 1.2	1915	1520	1420	1320
									20 / 1.4	2100	1720	1590	1470
									<b>23 / 1.6</b>	2340	1875	<b>1750</b>	1600
									26 / 1.8	2470	-	-	-
									28 / 1.9	2550	-	-	-
420/70 R28	TL	133 A8 / 133 B	W13	W12-W14L	413	1358	4033	610	9 / 0.6	1530	1215	1100	1015
									12 / 0.8	1790	1420	1330	1220
									15 / 1.0	2070	1630	1520	1410
									17 / 1.2	2270	1825	1710	1490
									20 / 1.4	2540	2015	1890	1740
									<b>23 / 1.6</b>	2750	2205	<b>2060</b>	1900
									26 / 1.8	2910	-	-	-
									28 / 1.9	2990	-	-	-
480/70 R28	TL	140 A8 / 140 B	W15L	W14L-W16L	476	1423	4200	637	9 / 0.6	1835	1500	1370	1240
									12 / 0.8	2145	1700	1600	1475
									15 / 1.0	2450	1960	1820	1680
									17 / 1.2	2760	2195	2050	1885
									20 / 1.4	3045	2450	2275	2090
									<b>23 / 1.6</b>	3325	2675	<b>2500</b>	2300
									26 / 1.8	3525	-	-	-
									28 / 1.9	3725	-	-	-

• Load capacity on recommended speed and pressure is stated with dark colour.



Tractor Radial • Characteristics of **TA 110/70**

Tire Size	TT/TL	Load/Speed Index	Rims		Inflated Dimensions (No Load)		Inflated Dimensions (W/Load)		Inflation Pressure (psi/bar)	Load capacity per tire, kg			
			Recom (inch)	Permitted (inch)	Section Width (mm)	Outer Diameter (mm)	Dynamic Rolling Circumference (mm)	Static Loaded Radius (mm)		Speed, km/h			
										10	30	40	50
420/70 R30	TL	134 A8 / 131 B	W13	W12- W14L	418	1398	4166	630	9 / 0.6	1535	1240	1140	-
									12 / 0.8	1820	1450	1365	1240
									15 / 1.0	2080	1670	1540	1425
									17 / 1.2	2350	1860	1740	1600
									20 / 1.4	2595	2075	1935	1780
									<b>23 / 1.6</b>	2830	2270	<b>2120</b>	1950
									26 / 1.8	3055	-	-	-
									28 / 1.9	3255	-	-	-
480/70 R30	TL	141 A8 / 138 B	W15L	W14L- W16L	478	1478	4389	660	9 / 0.6	1900	1515	-	-
									12 / 0.8	2200	1675	1680	1520
									15 / 1.0	2530	2010	1870	1700
									17 / 1.2	2850	2280	2125	1950
									20 / 1.4	3130	2525	2355	2130
									<b>23 / 1.6</b>	3460	2750	<b>2575</b>	2360
									26 / 1.8	3630	-	-	-
									28 / 1.9	3755	-	-	-
520/70 R30	TL	145 A8 / 142 B	W16L	W15L- W18L	516	1536	4560	683	9 / 0.6	2100	2000	1900	1720
									12 / 0.8	2340	2205	2070	1900
									15 / 1.0	2785	2460	2290	-
									17 / 1.2	3010	2600	2500	2270
									20 / 1.4	3130	2805	2680	2440
									<b>23 / 1.6</b>	3320	3100	<b>2900</b>	2650
									26 / 1.8	3510	-	-	-
									28 / 1.9	3630	-	-	-
480/70 R34	TL	143 A8 / 140 B	W15L	W14L- W16L	478	1580	4708	712	9 / 0.6	2100	1900	-	-
									12 / 0.8	2650	2125	1985	-
									15 / 1.0	2980	2330	2175	-
									17 / 1.2	3190	2545	2370	2065
									20 / 1.4	3420	2770	2540	2285
									<b>23 / 1.6</b>	3600	2915	<b>2725</b>	2500
									26 / 1.8	3820	-	-	-
									28 / 1.9	4010	-	-	-

• Load capacity on recommended speed and pressure is stated with dark colour.

**DESCRIPTION**

\* For load capacity on various speed ratings, and inflation figures, please consult your sales representative.

\*\* Load capacity on standard speed and weight

• Our company is entitled to make any change on any information in this catalogue, without further notice.

• This catalogue annuls all the previous catalogues

• All figures are for reference; our company is not responsible for printing errors.

## Tractor Radial • Characteristics of TA 110<sup>/70</sup>

Tire Size	TT/TL	Load/Speed Index	Rims		Inflated Dimensions (No Load)		Inflated Dimensions (W/Load)		Inflation Pressure (psi/bar)	Load capacity per tire, kg			
			Recom (inch)	Permitted (inch)	Section Width (mm)	Outer Diameter (mm)	Dynamic Rolling Circumference (mm)	Static Loaded Radius (mm)		Speed, km/h			
										10	30	40	50
520/70 R34	TL	148 A8 / 145 B	W16L	W15L- W18L	516	1640	4920	737	9 / 0.6	2400	1925	1800	1600
									12 / 0.8	2850	2290	2180	1900
									15 / 1.0	3180	2520	2370	2205
									17 / 1.2	3540	2830	2600	2470
									20 / 1.4	3910	3095	2870	2700
									<b>23 / 1.6</b>	4280	3370	<b>3150</b>	2900
									26 / 1.8	4480	-	-	-
28 / 1.9	4660	-	-	-									
480/70 R38	TL	145 A8 / 142 B	W15L	W14L- W16L	478	1681	4990	762	9 / 0.6	2200	1850	1600	1510
									12 / 0.8	2530	2110	1950	1750
									15 / 1.0	2925	2325	2180	1980
									17 / 1.2	3240	2600	2420	2240
									20 / 1.4	3600	2845	2660	2500
									<b>23 / 1.6</b>	3910	3105	<b>2900</b>	2650
									26 / 1.8	4160	-	-	-
28 / 1.9	4280	-	-	-									
520/70 R38	TL	150 A8 / 147 B	W16L	W15L- W18L	516	1749	5212	789	9 / 0.6	2700	2080	1850	1730
									12 / 0.8	2980	2350	2240	2035
									15 / 1.0	3395	2660	2530	2260
									17 / 1.2	3750	2970	2780	2530
									20 / 1.4	4130	3250	3040	2820
									<b>23 / 1.6</b>	4500	3585	<b>3350</b>	3075
									26 / 1.8	4760	-	-	-
28 / 1.9	4880	-	-	-									
580/70 R38	TL	155 A8 / 152 B	W18L	-	577	1827	5463	819	9 / 0.6	3070	2360	2120	1960
									12 / 0.8	3530	2750	2490	2290
									15 / 1.0	4000	3100	2830	2570
									17 / 1.2	4340	3500	3165	2920
									20 / 1.4	4800	3800	3515	3245
									<b>23 / 1.6</b>	5200	4135	<b>3875</b>	3550
									26 / 1.8	5550	-	-	-
28 / 1.9	5810	-	-	-									
580/70 R42	TL	158 A8 / 158 B	W12	W11	577	1879	5637	858.8	20 / 1.4	-	4140	3870	-
									22 / 1.5	-	4320	4040	-
									<b>23 / 1.6</b>	-	4550	<b>4250</b>	-

• Load capacity on recommended speed and pressure is stated with dark colour.



# A PERFECT WORLD.

In a perfect world, all your equipment is extremely strong, efficient & affordable.  
In real world, all you need is Petlas.



**petlas**



# TA 110<sup>/80</sup>

Tractor  
Radial

## PERFORMANCE INFORMATION

General purpose R1W farm front and rear tire with standard profile and tread design for high traction tractors



## FEATURES

### Long service life / Durability

- Strong carcass and impact ply
- Special tread compound provides high resistance against wear and cuts
- Tread profile provides high resistance against tread base fatigue and the tire maintains its traction performance even at its half-life

### Ease of use

- Special tread geometry provides self cleaning
- Strong and flexible sidewall
- Perfect grip/high traction with wide footprint

### Low soil compaction / Reduced slip

- Special tread structure provides high traction and less sinking at soft surfaces
- Wide footprint provides lower soil compaction
- Ensures a balanced steering by reduced slip at all surfaces

## SIZES

260/80 R20 • 480/80 R38 • 480/80 R42 • 480/80 R46 • 480/80 R50



# Tractor Radial • Characteristics of TA 110/80

Tire Size	TT/TL	Load/Speed Index	Rims		Inflated Dimensions (No Load)		Inflated Dimensions (W/Load)		Inflation Pressure (psi/bar)	Load capacity per tire, kg			
			Recom (inch)	Permitted (inch)	Section Width (mm)	Outer Diameter (mm)	Dynamic Rolling Circumference (mm)	Static Loaded Radius (mm)		Speed, km/h			
										10	30	40	50
260/80 R20	TL	106 A8 / 103 B	W8	W9	258	924	2795	430	9 / 0.6	740	650	-	-
									12 / 0.8	920	720	655	-
									15 / 1.0	1000	800	740	680
									17 / 1.2	1100	850	800	735
									20 / 1.4	1190	935	870	800
									<b>23 / 1.6</b>	1280	1010	<b>950</b>	875
									26 / 1.8	1330	-	-	-
28 / 1.9	1375	-	-	-									
480/80 R38	TL	149 A8 / 149 B	DW16L	W15L, W15A, W16A, DW16A, DD16	479	1733	5199	790	20 / 1.4	3640	3165	2960	-
									21 / 1.5	3815	3320	3105	-
									<b>23 / 1.6</b>	4000	3480	<b>3250</b>	-
480/80 R42	TL	151 A8 / 148 B	DW16L	DD16L-W16L	492	1858	5538	846	9 / 0.6	2720	1890	1790	1605
									12 / 0.8	3125	2285	2100	1980
									15 / 1.0	3670	2600	2400	2310
									17 / 1.2	4100	2910	2700	2600
									20 / 1.4	4630	3290	3095	2850
									<b>23 / 1.6</b>	5080	3600	<b>3450</b>	3150
									26 / 1.8	5280	-	-	-
28 / 1.9	5460	-	-	-									
480/80 R46	TL	158 A8 / 158 B	DW16L	DD16L-W16L	496	1952	5876	891	9 / 0.6	2895	2115	2000	2000
									12 / 0.8	3300	2490	2260	2260
									17 / 1.2	4100	3160	2730	2730
									23 / 1.6	4895	3855	3250	3250
									29 / 2.0	5390	4215	3760	3760
									<b>32 / 2.2</b>	5650	4390	4020	4020
<b>35 / 2.4</b>	5895	4580	<b>4250</b>	4250									
480/80 R50	TL	159 A8 / 159 B	DW16L	DW14L-W15L DW15L-W16L	496	2064	6192	945	9 / 0.6	3010	2240	2075	2075
									12 / 0.8	3480	2680	2390	2390
									17 / 1.2	4310	3355	3140	3140
									23 / 1.6	5280	4180	3900	3900
									29 / 2.0	6100	4445	4175	4175
									<b>32 / 2.2</b>	6200	4540	4270	4270
<b>35 / 2.4</b>	6340	4650	<b>4375</b>	4375									

• Load capacity on recommended speed and pressure is stated with dark colour.

## DESCRIPTION

\* For load capacity on various speed ratings, and inflation figures, please consult your sales representative.

\*\* Load capacity on standard speed and weight

- Our company is entitled to make any change on any information in this catalogue, without further notice.
- This catalogue annuls all the previous catalogues
- All figures are for reference; our company is not responsible for printing errors.

# TA 110/85

Tractor  
Radial

## PERFORMANCE INFORMATION

General purpose R1 farm front and rear tire with standard profile and tread design for high traction tractors



## FEATURES

### Long service life / Durability

- Strong carcass and impact ply
- Special tread compound provides high resistance against wear and cuts
- Tread profile provides high resistance against tread base fatigue and the tire maintains its traction performance even at its half-life

### Ease of use

- Special tread geometry provides self cleaning
- Strong and flexible sidewall
- Perfect grip/high traction with wide footprint

### Low soil compaction / Reduced slip

- Special tread structure provides high traction and less sinking at soft surfaces
- Wide footprint provides lower soil compaction
- Ensures a balanced steering by reduced slip at all surfaces

## SIZES

9.5 R20 • 9.5 R24 • 280/85 R20 • 320/85 R20 • 280/85 R24 • 320/85 R24 • 340/85 R24 • 380/85 R24 • 420/85 R24  
 280/85 R28 • 320/85 R28 • 340/85 R28 • 380/85 R28 • 420/85 R28 • 380/85 R30 • 420/85 R30 • 460/85 R30 • 320/85 R32  
 380/85 R34 • 420/85 R34 • 460/85 R34 • 320/85 R36 • 340/85 R36 • 320/85 R38 • 340/85 R38 • 380/85 R38 • 420/85 R38  
 460/85 R38 • 460/85 R38 RF • 520/85 R38 • 520/85 R38 RF • 650/85 R38 • 520/85 R42  
 520/85 R42 RF • 520/85 R46



## Tractor Radial • Characteristics of TA 110/85

Tire Size	TT/TL	Load/Speed Index	Rims		Inflated Dimensions (No Load)		Inflated Dimensions (W/Load)		Inflation Pressure (psi/bar)	Load capacity per tire, kg			
			Recom (inch)	Permitted (inch)	Section Width (mm)	Outer Diameter (mm)	Dynamic Rolling Circumference (mm)	Static Loaded Radius (mm)		Speed, km/h			
										10	30	40	50
9.5 R20	TL	108 A8 / 105 B	W8	W7	242	938	2848	430	9 / 0.6	800	540	470	
									12 / 0.8	930	640	580	500
									15 / 1.0	1040	820	670	600
									17 / 1.2	1150	910	795	695
									20 / 1.4	1270	995	910	805
									<b>23 / 1.6</b>	1395	1075	<b>1000</b>	925
									26 / 1.8	1455	-	-	-
28 / 1.9	1515	-	-	-									
9.5 R24	TL	107 A8 / 104 B	W8	W7	243	1040	3135	488	9 / 0.6	820	640	-	-
									12 / 0.8	1000	735	690	-
									15 / 1.0	1055	780	755	640
									17 / 1.2	1130	855	810	725
									20 / 1.4	1240	950	885	810
									<b>23 / 1.6</b>	1320	1035	<b>975</b>	900
									26 / 1.8	1410	-	-	-
28 / 1.9	1480	-	-	-									
280/85 R20	TL	112 A8 / 109 B	W10	W9	290	989	2955	446	9 / 0.6	800	650	600	530
									12 / 0.8	950	770	710	630
									15 / 1.0	1000	880	800	750
									17 / 1.2	1225	1000	920	850
									20 / 1.4	1350	1105	1025	940
									<b>23 / 1.6</b>	1480	1190	<b>1120</b>	1030
									26 / 1.8	1560	-	-	-
28 / 1.9	1630	-	-	-									
320/85 R20	TL	119 A8 / 116 B	W11	W9-W10	319	1052	3145	472	9 / 0.6	830	790	700	650
									12 / 0.8	970	920	840	790
									15 / 1.0	1305	1050	960	900
									17 / 1.2	1480	1190	1100	1040
									20 / 1.4	1630	1310	1225	1150
									<b>23 / 1.6</b>	1790	1435	<b>1360</b>	1250
									26 / 1.8	1870	-	-	-
28 / 1.9	1950	-	-	-									

• Load capacity on recommended speed and pressure is stated with dark colour.

### DESCRIPTION

\* For load capacity on various speed ratings, and inflation figures, please consult your sales representative.

\*\* Load capacity on standard speed and weight

- Our company is entitled to make any change on any information in this catalogue, without further notice.
- This catalogue annuls all the previous catalogues
- All figures are for reference; our company is not responsible for printing errors.

## Tractor Radial • Characteristics of TA 110 /85

Tire Size	TT/TL	Load/Speed Index	Rims		Inflated Dimensions (No Load)		Inflated Dimensions (W/Load)		Inflation Pressure (psi/bar)	Load capacity per tire, kg			
			Recom (inch)	Permitted (inch)	Section Width (mm)	Outer Diameter (mm)	Dynamic Rolling Circumference (mm)	Static Loaded Radius (mm)		Speed, km/h			
										10	30	40	50
280/85 R24	TL	115 A8 / 112 B	W10	W9	290	1089	3267	495	-	-	-	-	610
									12 / 0.8	1010	830	780	720
									15 / 1.0	1176	950	880	810
									17 / 1.2	1315	1065	1000	910
									20 / 1.4	1430	1180	1105	1010
									<b>23 / 1.6</b>	1580	1295	<b>1215</b>	1120
									26 / 1.8	1620	-	-	-
28 / 1.9	1655	-	-	-									
320/85 R24	TL	122 A8 / 119 B	W11	W9-W10	327	1155	3465	515	9 / 0.6	1090	860	800	715
									12 / 0.8	1270	1010	940	840
									15 / 1.0	1450	1075	1065	980
									17 / 1.2	1620	1305	1215	1105
									20 / 1.4	1810	1440	1350	1230
									<b>23 / 1.6</b>	1970	1600	<b>1500</b>	1360
									26 / 1.8	2165	-	-	-
28 / 1.9	2230	-	-	-									
320/85 R32	TL	126 A8 / 126 B	W11	W9, W10	319	1357	4071	624,6	20 / 1.4	-	3165	2960	-
									22 / 1.5	3815	3320	3105	-
									23 / 1.6	4000	3480	3250	-
340/85 R24	TL	125 A8 / 122 B	W12	W11	350	1194	3555	542	9 / 0.6	1230	940	890	790
									12 / 0.8	1450	1110	1030	930
									15 / 1.0	1620	1270	1190	1080
									17 / 1.2	1860	1470	1335	1200
									20 / 1.4	2060	1600	1495	1360
									<b>23 / 1.6</b>	2200	1760	<b>1650</b>	1500
									26 / 1.8	2350	-	-	-
28 / 1.9	2460	-	-	-									
380/85 R24	TL	131 A8	W12	W11-W13	388	1256	3750	560	9 / 0.6	1440	1140	1070	1020
									12 / 0.8	1690	1400	1270	1160
									15 / 1.0	2020	1580	1490	1320
									17 / 1.2	2165	1750	1640	1500
									20 / 1.4	2400	1920	1785	1650
									<b>23 / 1.6</b>	2625	2075	<b>1950</b>	1800
									26 / 1.8	2780	-	-	-
28 / 1.9	2900	-	-	-									

\* Load capacity on recommended speed and pressure is stated with dark colour.



## Tractor Radial • Characteristics of TA 110/85

Tire Size	TT/TL	Load/Speed Index	Rims		Inflated Dimensions (No Load)		Inflated Dimensions (W/Load)		Inflation Pressure (psi/bar)	Load capacity per tire, kg			
			Recom (inch)	Permitted (inch)	Section Width (mm)	Outer Diameter (mm)	Dynamic Rolling Circumference (mm)	Static Loaded Radius (mm)		Speed, km/h			
										10	30	40	50
420/85 R24	TL	137 A8 / 134 B	W15L	W13-W14L	424	1324	3958	591	9 / 0.6	1850	1550	-	-
									12 / 0.8	2300	1710	1670	1500
									15 / 1.0	2540	1950	1825	1715
									17 / 1.2	2720	2115	1970	1880
									20 / 1.4	2940	2280	2130	2090
									<b>23 / 1.6</b>	3150	2465	<b>2300</b>	2120
									26 / 1.8	3350	-	-	-
									28 / 1.9	3500	-	-	-
280/85 R28	TL	118 A8 / 115 B	W10	W9	290	1187	3560	542	9 / 0.6	990	825	700	650
									12 / 0.8	1160	930	860	800
									15 / 1.0	1320	1045	980	900
									17 / 1.2	1480	1175	1095	1020
									20 / 1.4	1625	1310	1210	1125
									<b>23 / 1.6</b>	1780	1410	<b>1320</b>	1215
									26 / 1.8	1840	-	-	-
									28 / 1.9	1970	-	-	-
320/85 R28	TL	124 A8 / 121 B	W11	W9-W10	319	1255	3752	574	9 / 0.6	1200	1000	890	800
									12 / 0.8	1400	1140	1050	950
									15 / 1.0	1620	1280	1190	1085
									17 / 1.2	1800	1430	1345	1225
									20 / 1.4	2000	1570	1470	1360
									<b>23 / 1.6</b>	2150	1710	<b>1600</b>	1450
									26 / 1.8	2230	-	-	-
									28 / 1.9	2310	-	-	-
340/85 R28	TL	127 A8 / 124 B	W12	W11	354	1287	3880	600	9 / 0.6	1325	165	980	860
									12 / 0.8	1540	1270	1150	1040
									15 / 1.0	1840	1425	1310	1185
									17 / 1.2	2040	1560	1450	1335
									20 / 1.4	2170	1720	1605	1480
									<b>23 / 1.6</b>	2360	1875	<b>1750</b>	1600
									26 / 1.8	2420	-	-	-
									28 / 1.9	2530	-	-	-

• Load capacity on recommended speed and pressure is stated with dark colour.

### DESCRIPTION

\* For load capacity on various speed ratings, and inflation figures, please consult your sales representative.

\*\* Load capacity on standard speed and weight

- Our company is entitled to make any change on any information in this catalogue, without further notice.
- This catalogue annuls all the previous catalogues
- All figures are for reference; our company is not responsible for printing errors.

## Tractor Radial • Characteristics of TA 110/85

Tire Size	TT/TL	Load/Speed Index	Rims		Inflated Dimensions (No Load)		Inflated Dimensions (W/Load)		Inflation Pressure (psi/bar)	Load capacity per tire, kg			
			Recom (inch)	Permitted (inch)	Section Width (mm)	Outer Diameter (mm)	Dynamic Rolling Circumference (mm)	Static Loaded Radius (mm)		Speed, km/h			
										10	30	40	50
380/85 R28	TL	133 A8 / 130 B	W12	W11-W13	388	1355	4089	612	9 / 0.6	1580	1250	1155	1060
									12 / 0.8	1900	1430	1360	1250
									15 / 1.0	2010	1650	1550	1415
									17 / 1.2	2350	1850	1715	1580
									20 / 1.4	2550	2020	1890	1755
									<b>23 / 1.6</b>	<b>2780</b>	<b>2205</b>	<b>2060</b>	1900
									26 / 1.8	2815	-	-	-
									28 / 1.9	2910	-	-	-
420/85 R28	TL	139 A8 / 136 B	W15L	W13-W14L	418	1425	4261	635	9 / 0.6	1700	1500	1470	1300
									12 / 0.8	2300	1760	1655	1480
									15 / 1.0	2500	1985	1915	1760
									17 / 1.2	2740	2180	2035	1900
									20 / 1.4	2985	2400	2235	2085
									<b>23 / 1.6</b>	<b>3280</b>	<b>2600</b>	<b>2430</b>	2240
									26 / 1.8	3350	-	-	-
									28 / 1.9	3460	-	-	-
380/85 R30	TL	135 A8 / 132 B	W12	W11-W13	388	1404	4236	634	9 / 0.6	1600	1275	1190	1100
									12 / 0.8	1875	1480	1380	1300
									15 / 1.0	2135	1690	1570	1585
									17 / 1.2	2380	1910	1775	1720
									20 / 1.4	2620	2115	1975	1845
									<b>23 / 1.6</b>	<b>2870</b>	<b>2325</b>	<b>2180</b>	2000
									26 / 1.8	3140	-	-	-
									28 / 1.9	3360	-	-	-
420/85 R30	TL	140 A8 / 137 B	W15L	W13-W14L	420	1475	4455	660	9 / 0.6	1800	1410	1365	1215
									12 / 0.8	2140	1670	1580	1440
									15 / 1.0	2440	1940	1810	1640
									17 / 1.2	2680	2180	1990	1830
									20 / 1.4	3030	2400	2240	2070
									<b>23 / 1.6</b>	<b>3340</b>	<b>2640</b>	<b>2500</b>	2300
									26 / 1.8	3450	-	-	-
									28 / 1.9	3550	-	-	-

• Load capacity on recommended speed and pressure is stated with dark colour.



# Tractor Radial • Characteristics of TA 110 /85

Tire Size	TT/TL	Load/Speed Index	Rims		Inflated Dimensions (No Load)		Inflated Dimensions (W/Load)		Inflation Pressure (psi/bar)	Load capacity per tire, kg			
			Recom (inch)	Permitted (inch)	Section Width (mm)	Outer Diameter (mm)	Dynamic Rolling Circumference (mm)	Static Loaded Radius (mm)		Speed, km/h			
										10	30	40	50
460/85 R30	TL	145 A8 / 142 B	W16L	W14L- W15L	466	1552	4683	694	9 / 0.6	2100	1660	1540	1440
									12 / 0.8	2400	1960	1850	1550
									15 / 1.0	2815	2220	2090	1900
									17 / 1.2	3145	2510	2350	2100
									20 / 1.4	3510	2790	2625	2400
									<b>23 / 1.6</b>	3860	3100	<b>2900</b>	2650
									26 / 1.8	3985	-	-	-
									28 / 1.9	4100	-	-	-
380/85 R34	TL	137 A8 / 137 B	W12	W11-W13	391	1506	4468	674	9 / 0.6	1700	1345	1260	1260
									12 / 0.8	1975	1565	1470	1470
									15 / 1.0	2255	1795	1675	1675
									17 / 1.2	2520	2020	1875	1875
									20 / 1.4	2800	2235	2085	2085
									<b>23 / 1.6</b>	3060	2445	<b>2300</b>	
									26 / 1.8	3320	-	-	-
									28 / 1.9	3500	-	-	-
420/85 R34	TL	142 A8 / 139 B	W15L	W13- W14L	420	1580	4750	715	9 / 0.6	2070	1555	1455	1330
									12 / 0.8	2350	1815	1695	1565
									15 / 1.0	2625	2070	1935	1740
									17 / 1.2	2910	2330	2170	2000
									20 / 1.4	3210	2585	2410	2220
									<b>23 / 1.6</b>	3535	2835	<b>2650</b>	2430
									26 / 1.8	3840	-	-	-
									28 / 1.9	4000	-	-	-
460/85 R34	TL	147 A8 / 144 B	W16L	W14L- W15L	466	1653	4965	750	9 / 0.6	2250	1805	1680	1490
									12 / 0.8	2620	2095	1950	1785
									15 / 1.0	2985	2400	2230	2040
									17 / 1.2	3320	2700	2525	2285
									20 / 1.4	3740	2985	2790	2540
									<b>23 / 1.6</b>	4115	3290	<b>3075</b>	2800
									26 / 1.8	4365	-	-	-
									28 / 1.9	4475	-	-	-

• Load capacity on recommended speed and pressure is stated with dark colour.

## DESCRIPTION

\* For load capacity on various speed ratings, and inflation figures, please consult your sales representative.

\*\* Load capacity on standard speed and weight

- Our company is entitled to make any change on any information in this catalogue, without further notice.
- This catalogue annuls all the previous catalogues
- All figures are for reference; our company is not responsible for printing errors.

## Tractor Radial • Characteristics of TA 110/85

Tire Size	TT/TL	Load/Speed Index	Rims		Inflated Dimensions (No Load)		Inflated Dimensions (W/Load)		Inflation Pressure (psi/bar)	Load capacity per tire, kg			
			Recom (inch)	Permitted (inch)	Section Width (mm)	Outer Diameter (mm)	Dynamic Rolling Circumference (mm)	Static Loaded Radius (mm)		Speed, km/h			
										10	30	40	50
320/85 R36	TL	128 A8 / 125 B	W11	W9-W10	328	1457	4364	671	9 / 0.6	1290	1045	975	900
									12 / 0.8	1515	1200	1125	1045
									15 / 1.0	1750	1380	1305	1190
									17 / 1.2	1970	1545	1470	1320
									20 / 1.4	2190	1750	1630	1485
									<b>23 / 1.6</b>	2405	1920	<b>1800</b>	1650
									26 / 1.8	2490	-	-	-
									28 / 1.9	2590	-	-	-
340/85 R36	TL	132 A8 / 129 B	W12	W11	352	1496	4482	685	9 / 0.6	1455	1140	1090	1010
									12 / 0.8	1690	1350	1270	1170
									15 / 1.0	1940	1565	1450	1345
									17 / 1.2	2180	1745	1625	1500
									20 / 1.4	2400	1935	1810	1650
									<b>23 / 1.6</b>	2630	2130	<b>2000</b>	1850
									26 / 1.8	2720	-	-	-
									28 / 1.9	2790	-	-	-
320/85 R38	TL	143A8 / 143 B	W10	W9-W11-DW11	315	1510	4515	698	9 / 0.6	1590	1300	-	-
									12 / 0.8	2015	1645	1550	-
									15 / 1.0	2180	1790	1685	1685
									17 / 1.2	2370	1935	1825	1825
									20 / 1.4	2580	2105	1980	1980
									23 / 1.6	2690	2195	2070	2070
									26 / 1.8	2795	2280	2150	2150
									28 / 1.9	2900	2370	2235	2235
									29 / 2.0	3040	2485	2340	2340
									<b>35 / 2.4</b>	3540	2890	<b>2725</b>	2725
340/85 R38	TL	133 A8 / 130 B	W12	W11	354	1555	4675	715	9 / 0.6	1500	1200	1125	990
									12 / 0.8	1750	1410	1310	1200
									15 / 1.0	2000	1590	1490	1380
									17 / 1.2	2245	1800	1675	1545
									20 / 1.4	2520	2005	1865	1720
									<b>23 / 1.6</b>	2750	2200	<b>2060</b>	1900
									26 / 1.8	2835	-	-	-
									28 / 1.9	2920	-	-	-

• Load capacity on recommended speed and pressure is stated with dark colour.



# Tractor Radial • Characteristics of TA 110 /85

Tire Size	TT/TL	Load/Speed Index	Rims		Inflated Dimensions (No Load)		Inflated Dimensions (W/Load)		Inflation Pressure (psi/bar)	Load capacity per tire, kg			
			Recom (inch)	Permitted (inch)	Section Width (mm)	Outer Diameter (mm)	Dynamic Rolling Circumference (mm)	Static Loaded Radius (mm)		Speed, km/h			
										10	30	40	50
380/85 R38	TL	139 A8 / 136 B	W12	W11- W13	388	1612	4833	742	9 / 0.6	2180	1700	1540	1420
									12 / 0.8	2380	1870	1760	1600
									15 / 1.0	2630	2040	1930	1710
									17 / 1.2	2830	2200	2080	1900
									20 / 1.4	3070	2410	2250	2020
									<b>23 / 1.6</b>	<b>3300</b>	<b>2585</b>	<b>2430</b>	<b>2240</b>
									26 / 1.8	3445	-	-	-
									28 / 1.9	3545	-	-	-
420/85 R38	TL	144 A8 / 141 B	W15L	W13- W14L	430	1675	5042	762	9 / 0.6	2200	1645	1540	1425
									12 / 0.8	2480	1915	1800	1670
									15 / 1.0	2775	2190	2050	1895
									17 / 1.2	3070	2460	2300	2145
									20 / 1.4	3390	2730	2550	2365
									<b>23 / 1.6</b>	<b>3725</b>	<b>3000</b>	<b>2800</b>	<b>2575</b>
									26 / 1.8	4030	-	-	-
									28 / 1.9	4230	-	-	-
460/85 R38	TL	149 A8 / 146 B	W16L	W14L- W15L	466	1747	5270	805	9 / 0.6	2380	1900	1780	1640
									12 / 0.8	2700	2200	2060	1880
									15 / 1.0	3170	2425	2370	2120
									17 / 1.2	3520	2835	2650	2450
									20 / 1.4	3935	3140	2950	2710
									<b>23 / 1.6</b>	<b>4350</b>	<b>3460</b>	<b>3250</b>	<b>2960</b>
									26 / 1.8	4630	-	-	-
									28 / 1.9	4750	-	-	-
460/85 R38 REINFORCED	TL	149 A8 / 146 B	W16L	W14L- W15L	466	1747	5270	805	9 / 0.6	2380	1900	1780	1640
									12 / 0.8	2700	2200	2060	1880
									15 / 1.0	3170	2425	2370	2120
									17 / 1.2	3520	2835	2650	2450
									20 / 1.4	3935	3140	2950	2710
									<b>23 / 1.6</b>	<b>4350</b>	<b>3460</b>	<b>3250</b>	<b>3000</b>
									26 / 1.8	4630	-	-	-
									28 / 1.9	4750	-	-	-

• Load capacity on recommended speed and pressure is stated with dark colour.

## DESCRIPTION

\* For load capacity on various speed ratings, and inflation figures, please consult your sales representative.

\*\* Load capacity on standard speed and weight

- Our company is entitled to make any change on any information in this catalogue, without further notice.
- This catalogue annuls all the previous catalogues
- All figures are for reference; our company is not responsible for printing errors.

## Tractor Radial • Characteristics of TA 110 /85

Tire Size	TT/TL	Load/Speed Index	Rims		Inflated Dimensions (No Load)		Inflated Dimensions (W/Load)		Inflation Pressure (psi/bar)	Load capacity per tire, kg			
			Recom (inch)	Permitted (inch)	Section Width (mm)	Outer Diameter (mm)	Dynamic Rolling Circumference (mm)	Static Loaded Radius (mm)		Speed, km/h			
										10	30	40	50
520/85 R38	TL	155 A8 / 152 B	DW16L	DW18L	516	1849	5529	828	9 / 0.6	3000	2300	2120	1970
									12 / 0.8	3450	2655	2500	2290
									15 / 1.0	3850	3050	2825	2600
									17 / 1.2	4255	3450	3170	2925
									20 / 1.4	4710	3790	3520	3250
									<b>23 / 1.6</b>	5150	4145	<b>3875</b>	3550
									26 / 1.8	5550	-	-	-
28 / 1.9	5825	-	-	-									
520/85 R38 REINFORCED	TL	155 A8 / 152 B	DW16L DD16L	DW18L	516	1849	5547	837	25 / 1.7	-	3865	3615	-
									28 / 1.9	-	4055	3790	-
									<b>30 / 2.0</b>	-	4145	<b>3875</b>	-
650/85 R38	TL	173 A8 / 173 B	DW23B	DW20B DW21B	680	2065	6095	922	9 / 0.6	4500	3400	3200	-
									12 / 0.8	5670	4380	4095	-
									15 / 1.0	6390	4935	4615	4615
									17 / 1.2	-	5215	4875	4875
									20 / 1.4	7020	5420	5070	5070
									23 / 1.6	7470	5770	5395	5395
									26 / 1.8	7920	6120	5720	5720
									28 / 1.9	8100	6255	5850	5850
									29 / 2.0	8280	6395	5980	5980
									<b>35 / 2.4</b>	9000	6955	<b>6500</b>	6500
520/85 R42	TL	157 A8 / 157 B	DW18L	DW16L	537	1950	5850	875	9 / 0.6	3200	2400	2260	2260
									12 / 0.8	3500	2815	2610	2610
									15 / 1.0	4070	3200	2990	2990
									17 / 1.2	4510	3605	3375	3375
									20 / 1.4	5015	4015	3745	3745
									<b>23 / 1.6</b>	5500	4400	<b>4125</b>	4125
									26 / 1.8	5865	-	-	-
28 / 1.9	6150	-	-	-									

• Load capacity on recommended speed and pressure is stated with dark colour.



Tractor Radial • Characteristics of **TA 110/85**

Tire Size	TT/TL	Load/Speed Index	Rims		Inflated Dimensions (No Load)		Inflated Dimensions (W/Load)		Inflation Pressure (psi/bar)	Load capacity per tire, kg			
			Recom (inch)	Permitted (inch)	Section Width (mm)	Outer Diameter (mm)	Dynamic Rolling Circumference (mm)	Static Loaded Radius (mm)		Speed, km/h			
										10	30	40	50
520/85 R42 REINFORCED	TL	162 A8 / 162 B	DW18L	DW16L	537	1950	5850	875	9 / 0.6	3470	2860	-	-
									12 / 0.8	3895	3205	2995	2995
									15 / 1.0	4285	3530	3300	3300
									17 / 1.2	4650	3825	3575	3575
									20 / 1.4	5100	4100	3840	3840
									23 / 1.6	5650	4500	4200	4200
									29 / 2.0	5925	4900	4520	4520
									<b>35 / 2.4</b>	6400	5150	<b>4750</b>	4750
44 / 3.0	7170	-	-	-									
520/85 R46	TL	158 A8 / 155 B	DW16L	DW18L	516	2050	6090	922	9 / 0.6	3300	2500	2300	-
									12 / 0.8	3740	2900	2690	2470
									15 / 1.0	4250	3470	3280	3000
									17 / 1.2	4650	3800	3525	3210
									20 / 1.4	5050	4160	3900	3580
									<b>23 / 1.6</b>	5465	4550	<b>4250</b>	3875
									26 / 1.8	6025	-	-	-
									28 / 1.9	6365	-	-	-

• Load capacity on recommended speed and pressure is stated with dark colour.



**DESCRIPTION**

- \* For load capacity on various speed ratings, and inflation figures, please consult your sales representative.
- \*\* Load capacity on standard speed and weight

- Our company is entitled to make any change on any information in this catalogue, without further notice.
- This catalogue annuls all the previous catalogues
- All figures are for reference; our company is not responsible for printing errors.

# TA 130<sup>/65</sup>

Tractor Radial

## PERFORMANCE INFORMATION

General purpose R1W farm front and rear tire with tread design for high power tractors.



## FEATURES

### Long service life / Durability

- Strong carcass and impact ply
- Special tread compound provides high resistance against wear and cuts
- Tread profile provides high resistance against tread base fatigue and the tire maintains its traction performance even at its half-life

### High Traction / Self Cleaning

- Special tread geometry provides self cleaning
- Strong and flexible sidewall
- Perfect grip/high traction with wide footprint

### Low soil compaction / Reduced slip

- Special tread structure provides high traction and less sinking at soft surfaces
- Wide footprint provides lower soil compaction
- Ensures a balanced steering by reduced slip at all surfaces

**SIZES** 600/65 R28 · 600/65 R42 · 650/65 R42



## Tractor Radial • Characteristics of **TA 130 /65**

Tire Size	TT/TL	Load/Speed Index	Rims		Inflated Dimensions (No Load)		Inflated Dimensions (W/Load)		Inflation Pressure (psi/bar)	Load capacity per tire, kg				
			Recom (inch)	Permitted (inch)	Section Width (mm)	Outer Diameter (mm)	Dynamic Rolling Circumference (mm)	Static Loaded Radius (mm)		Speed, km/h				
										20	30	40	50	65
600/65 R28	TL	154D/157A8	DW20B	W18L	591	1491	4473	683	29 / 2,0	5175	3970	3795	3625	3450
									32 / 2,2	5400	4140	3960	3780	3600
									<b>35 / 2,4</b>	5625	4315	<b>4125</b>	3940	3750
600/65 R42	TL	154D/157A8	DW20B	W18L	591	1847	5541	860	17 / 1,2	4725	3625	3465	3310	3150
									20 / 1,4	5175	3970	3795	3625	3450
									<b>23 / 1,6</b>	5625	4315	<b>4125</b>	3940	3750
650/65 R42	TL	170 D/173A8	DW20B	-	645	1913	5739	853,16	40 / 2,8	6865	6415	6110	5860	5580
									43 / 3,0	7120	6660	6340	6080	5790
									<b>46 / 3,2</b>	7380	6900	6570	6300	<b>6000</b>

• Load capacity on recommended speed and pressure is stated with dark colour.



### DESCRIPTION

\* For load capacity on various speed ratings, and inflation figures, please consult your sales representative.

\*\* Load capacity on standard speed and weight

- Our company is entitled to make any change on any information in this catalogue, without further notice.
- This catalogue annuls all the previous catalogues
- All figures are for reference; our company is not responsible for printing errors.

**petras**

# TA 130<sup>/70</sup>

Tractor Radial

## PERFORMANCE INFORMATION

General purpose R1W farm front and rear tire with tread design for high power tractors.



## FEATURES

### Long service life / Durability

- Strong carcass and impact ply
- Special tread compound provides high resistance against wear and cuts
- Tread profile provides high resistance against tread base fatigue and the tire maintains its traction performance even at its half-life

### High Traction / Self Cleaning

- Special tread geometry provides self cleaning
- Strong and flexible sidewall
- Perfect grip/high traction with wide footprint

### Low soil compaction / Reduced slip

- Special tread structure provides high traction and less sinking at soft surfaces
- Wide footprint provides lower soil compaction
- Ensures a balanced steering by reduced slip at all surfaces

**SIZES** 600/70 R28 • 600/70 R30 • 600/70 R34 • 710/70 R38 • 800/70 R38  
620/70 R42 • 710/70 R42



# Tractor Radial • Characteristics of TA 130 /70

Tire Size	TT/TL	Load/Speed Index	Rims		Inflated Dimensions (No Load)		Inflated Dimensions (W/Load)		Inflation Pressure (psi/bar)	Load capacity per tire, kg				
			Recom (inch)	Permitted (inch)	Section Width (mm)	Outer Diameter (mm)	Dynamic Rolling Circumference (mm)	Static Loaded Radius (mm)		Speed, km/h				
										20	30	40	50	65
600/70 R28	TL	161 D	DW20B	DW18L, W18L	591	1551	4653	692	29 / 2,0	4770	4460	4245	4070	3880
									32 / 2,2	4920	4600	4380	4200	4000
									<b>35 / 2,4</b>	5075	4745	4515	4330	<b>4125</b>
600/70 R30	TL	158 D	DW20B	DW18L, W18L	591	1602	4806	717	29 / 2,0	4915	4595	4375	4195	3995
									32 / 2,2	5070	4740	4515	4330	4125
									<b>35 / 2,4</b>	5230	4890	4655	4465	<b>4250</b>
600/70 R34	TL	160 D	DW18B	DW20L, W18L	591	1723	5169	776	29 / 2,0	5205	4865	4630	4440	4230
									32 / 2,2	5370	5020	4780	4585	4365
									<b>35 / 2,4</b>	5535	5175	4930	4725	<b>4500</b>
	171 D	DW23B	-	716	1959	5877	941	29 / 2,0	7110	6650	6330	6070	5780	
								32 / 2,2	7340	6860	6530	6265	5965	
								<b>35 / 2,4</b>	7565	7075	6735	6460	<b>6150</b>	
710/70 R38	TL	171 D / 174 A8	DW23B	-	716	1959	5877	941	29 / 2,0	7110	6650	6330	6070	5780
									32 / 2,2	7340	6860	6530	6265	5965
									<b>35 / 2,4</b>	7565	7075	6735	6460	<b>6150</b>
800/70 R38	TL	178 D / 181 A8	DW25B	DW27B	795	2055	6090	905	29 / 2,0	8670	8110	7720	7260	7050
									32 / 2,2	8950	8365	7965	7495	7275
									<b>35 / 2,4</b>	9225	8625	8210	7725	<b>7500</b>
620/70 R42	TL	166 D	DW20B	-	625	1971	5913	891	29 / 2,0	6130	5730	5455	5230	4980
									32 / 2,2	6325	5910	5630	5400	5140
									<b>35 / 2,4</b>	6520	6095	5805	5565	<b>5300</b>
710/70 R42	TL	173 D / 176 A8	DW23B	-	716	2061	6183	891	29 / 2,0	7515	7030	6690	6415	6110
									32 / 2,2	7755	7250	6905	6620	6305
									<b>35 / 2,4</b>	7995	7475	7120	6825	<b>6500</b>

• Load capacity on recommended speed and pressure is stated with dark colour.

## DESCRIPTION

\* For load capacity on various speed ratings, and inflation figures, please consult your sales representative.  
 \*\* Load capacity on standard speed and weight

- Our company is entitled to make any change on any information in this catalogue, without further notice.
- This catalogue annuls all the previous catalogues
- All figures are for reference; our company is not responsible for printing errors.

# TA 130/70 IF SERIES

Tractor Radial

## PERFORMANCE INFORMATION

General purpose R1W farm front and rear tire with improved flexion (IF) technology designed for high power tractors.



## FEATURES

### Long service life / Durability

- With Improved flexible sidewalls, thanks to improved flexion technology, high traction at low tire pressure level without no harm to crops.
- Reinforced sidewalls with improved flexion technology allow to carry more load compare to other tires at the same pressure level

### High Traction / Self Cleaning

- Special tread geometry provides self cleaning
- Strong and flexible sidewall
- Perfect grip/high traction with wide footprint

### Low soil compaction / Reduced slip

- Special tread structure provides high traction and less sinking at soft surfaces
- Wide footprint provides lower soil compaction
- Ensures a balanced steering by reduced slip at all surfaces

**SIZES** IF 600/70 R30 • IF 800/70 R38



## Tractor Radial • Characteristics of TA 130 /70 IF SERIES

Tire Size	TT/TL	Load/Speed Index	Rims		Inflated Dimensions (No Load)		Inflated Dimensions (W/Load)		Inflation Pressure (psi/bar)	Load capacity per tire, kg				
			Recom (inch)	Permitted (inch)	Section Width (mm)	Outer Diameter (mm)	Dynamic Rolling Circumference (mm)	Static Loaded Radius (mm)		Speed, km/h				
										20	30	40	50	65
IF 600/70 R30	TL	165 D	21.00	20.00	625	1585	4690	702	12 / 0,8	-	-	2785	2785	2785
									14 / 1,0	-	-	3195	3195	3195
									17 / 1,2	-	-	3605	3605	3605
									21 / 1,4	-	-	4020	4020	4020
									23 / 1,6	-	-	4430	4430	4430
									29 / 2,0	-	-	4790	4790	4790
									<b>35 / 2,4</b>	-	-	5150	5150	<b>5150</b>
IF 800/70 R38	TL	184 D	27.00	25.00	815	2085	6150	924	12 / 0,8	-	-	-	4860	4860
									14 / 1,0	-	-	-	5580	5580
									17 / 1,2	-	-	-	6300	6300
									21 / 1,4	-	-	-	7020	7020
									23 / 1,6	-	-	-	7740	7740
									27 / 1,8	-	-	-	8000	8000
									29 / 2,0	-	-	-	8460	8460
									<b>31 / 2,2</b>	-	-	-	8750	<b>8750</b>
									29 / 2,0	8670	8110	7720	7260	7050
									32 / 2,2	8950	8365	7965	7495	7275
									<b>35 / 2,4</b>	9225	8625	8210	7725	<b>7500</b>

\* Load capacity on recommended speed and pressure is stated with dark colour.

IF: Improved Flexion

### DESCRIPTION

- \* For load capacity on various speed ratings, and inflation figures, please consult your sales representative.
- \*\* Load capacity on standard speed and weight

- Our company is entitled to make any change on any information in this catalogue, without further notice.
- This catalogue annuls all the previous catalogues
- All figures are for reference; our company is not responsible for printing errors.

# TA 130 /75 AGROPER

Harvester

## PERFORMANCE INFORMATION

General purpose use harvester front tire with **R1W** tread profile design and strong aramid belt structure.



## FEATURES

### Long service life / Durability

- Strong carcass and impact ply
- Special tread compound provides high resistance against wear and cuts
- Tread profile provides high resistance against tread base fatigue and the tire maintains its traction performance even at its half-life

### High Traction / Self Cleaning

- Special tread geometry provides self cleaning
- Strong and flexible sidewall
- Perfect grip/high traction with wide footprint

### Low soil compaction

#### / Reduced slip

- Special tread structure provides high traction and less sinking at soft surfaces
- Wide footprint provides lower soil compaction
- Ensures a balanced steering by reduced slip at all surfaces

**SIZES** 620/75 R26 • 620/75 R30 • 650/75 R32



## Harvester • Characteristics of TA 130 /75 AGROPER

Tire Size	TT/TL	Load/Speed Index	Rims		Inflated Dimensions (No Load)		Inflated Dimensions (W/Load)		Inflation Pressure (psi/bar)	Load capacity per tire, kg			
			Recom (inch)	Permitted (inch)	Section Width (mm)	Outer Diameter (mm)	Dynamic Rolling Circumference (mm)	Static Loaded Radius (mm)		Speed, km/h			
										20	30	40	50
620/75 R26	TL	166 A8 / 166 B	DW20B	-	645	1590	4739	703	41 / 2.8	6000	5220	4875	4875
									43 / 3.0	6260	545	5090	5090
									<b>46 / 3.2</b>	6520	5670	5300	<b>5300</b>
620/75 R30	TL	163 A8 / 160 B	DW20B	-	645	1692	5030	743	29 / 2.0	4760	4140	3870	3870
									35 / 2.4	5150	4480	4185	4185
									<b>40 / 2.8</b>	5535	4815	4500	<b>4500</b>
650/75 R32	TL	172 A8 / 172 B	DW21B	DW20B, DW23B	645	1789	5367	788	41 / 2,8	8700	6200	5800	5800
									44 / 3,0	9075	6475	6050	6050
									<b>46 / 3,2</b>	9450	6740	6300	<b>6300</b>

• Load capacity on recommended speed and pressure is stated with dark colour.



### DESCRIPTION

\* For load capacity on various speed ratings, and inflation figures, please consult your sales representative.

\*\* Load capacity on standard speed and weight

- Our company is entitled to make any change on any information in this catalogue, without further notice.
- This catalogue annuls all the previous catalogues
- All figures are for reference; our company is not responsible for printing errors.

**petlas**

# TA 140

Tractor  
Radial

## PERFORMANCE INFORMATION

General purpose R1W farm front and rear tire with standard profile and tread design for high power tractors and harvester



## FEATURES

### Long service life / Durability

- Strong carcass and impact ply
- Special tread compound provides high resistance against wear and cuts
- Tread profile provides high resistance against tread base fatigue and the tire maintains its traction performance even at its half-life

### Ease of use

- Special tread geometry provides self cleaning
- Strong and flexible sidewall
- Perfect grip/high traction with wide footprint

### Low soil compaction

#### / Reduced slip

- Special tread structure provides high traction and less sinking at soft surfaces
- Wide footprint provides lower soil compaction
- Ensures a balanced steering by reduced slip at all surfaces

**SIZES** 340/85 R28



## Tractor Radial • Characteristics of TA 140

Tire Size	TT/TL	Load/ Speed Index	Rims		Inflated Dimensions (No Load)		Inflated Dimensions (W/Load)		Inflation Pressure (psi/bar)	Load capacity per tire, kg			
			Recom (inch)	Permitted (inch)	Section Width (mm)	Outer Diameter (mm)	Dynamic Rolling Circumference (mm)	Static Loaded Radius (mm)		Speed, km/h			
										10	30	40	50
340/85 R28	TL	127 A8 / 124 B	W12	W11	354	1304	3940	606	9 / 0.6	1325	165	980	860
									12 / 0.8	1540	1270	1150	1040
									15 / 1.0	1840	1425	1310	1185
									17 / 1.2	2040	1560	1450	1335
									20 / 1.4	2170	1720	1605	1480
									<b>23 / 1.6</b>	2360	1875	<b>1750</b>	1600
									26 / 1.8	2420	-	-	-
									28 / 1.9	2530	-	-	-

• Load capacity on recommended speed and pressure is stated with dark colour.



### DESCRIPTION

\* For load capacity on various speed ratings, and inflation figures, please consult your sales representative.

\*\* Load capacity on standard speed and weight

- Our company is entitled to make any change on any information in this catalogue, without further notice.
- This catalogue annuls all the previous catalogues
- All figures are for reference; our company is not responsible for printing errors.

**petlas**

# TA 120

Row  
Crop

## PERFORMANCE INFORMATION

General purpose R1W farm front and rear tire with narrow profile and tread design for sprayers and row crop tractors



## FEATURES

### Long service life / Durability

- Strong carcass and impact ply
- Special tread compound provides high resistance against wear and cuts
- Tread profile provides high resistance against tread base fatigue and the tire maintains its traction performance even at its half-life

### Narrow Profile / Crop Production

- Narrow profile and special tread design eliminates crop damage

### Low soil compaction / Reduced slip

- Strong tread and carcass structure provide high traction under heavy load.

## SIZES

210/95 R32 • 230/95 R32 • 270/95 R32 • 210/95 R36 • 230/95 R36 • 270/95 R38  
230/95 R40 • 210/95 R44 • 230/95 R44 • 270/95 R44 • 300/95 R46 • 340/85 R48  
230/95 R48 • 270/95 R48 • 300/95 R52 • 270/95 R54 • 380/90 R46



## Row Crop • Characteristics of TA 120

Tire Size	TT/TL	Load/Speed Index	Rims		Inflated Dimensions (No Load)		Inflated Dimensions (W/Load)		Inflation Pressure (psi/bar)	Load capacity per tire, kg			
			Recom (inch)	Permitted (inch)	Section Width (mm)	Outer Diameter (mm)	Dynamic Rolling Circumference (mm)	Static Loaded Radius (mm)		Speed, km/h			
										10	30	40	50
210/95 R32	TL	114 A8 / 114 B	W7	W6	211	1212	3676	571	17 / 1.2	1025	885	825	825
									23 / 1.6	1100	1085	1015	1015
									29 / 2.0	1240	1175	1095	1095
									<b>35 / 2.4</b>	1350	1260	<b>1180</b>	1180
230/95 R32	TL	126 A8 / 126 B	W7	W8	230	1255	3799	593	20 / 1.4	1125	1070	1000	1000
									23 / 1.6	1260	1165	1085	1085
									29 / 2.0	1380	1270	1190	1190
									35 / 2.4	1630	1365	1275	1275
									40 / 2.8	1850	1490	1390	1390
									46 / 3.2	2000	1620	1510	1510
<b>58 / 4.0</b>	2200	1820	<b>1700</b>	1700									
270/95 R32	TL	136 A8 / 136 B	W9	W8, W10	275	1327	3981	618	49 / 3.4	3110	2215	2070	2070
									52 / 3.6	3160	2250	2105	2105
									58 / 4.0	3360	2395	2240	2040
210/95 R36	TL	116 A8 / 116 B	W7	W6	211	1314	3985	621	17 / 1.2	1025	935	875	875
									23 / 1.6	1270	1150	1075	1075
									29 / 2.0	1380	1244	1160	1160
									<b>35 / 2.4</b>	1520	1335	<b>1250</b>	1250
230/95 R36	TL	128 A8 / 128 B	W7	W8	230	1358	4117	644	20 / 1.4	1220	1135	1060	1060
									23 / 1.6	1330	1230	1150	1150
									29 / 2.0	1425	1345	1260	1260
									35 / 2.4	1640	1445	1350	1350
									40 / 2.8	1750	1580	1475	1475
									46 / 3.2	1940	1715	1600	1600
<b>58 / 4.0</b>	2300	1925	<b>1800</b>	1800									
270/95 R38	TL	140 A8 / 140 B	W9	W8, W10	275	1479	4437	673	49 / 3.4	3470	2475	2310	2310
									52 / 3.6	3525	2515	2350	2350
									58 / 4.0	3750	2675	2500	2500

• Load capacity on recommended speed and pressure is stated with dark colour.

### DESCRIPTION

\* For load capacity on various speed ratings, and inflation figures, please consult your sales representative.

\*\* Load capacity on standard speed and weight

- Our company is entitled to make any change on any information in this catalogue, without further notice.
- This catalogue annuls all the previous catalogues
- All figures are for reference; our company is not responsible for printing errors.

**petlas**

## Row Crop Characteristics of TA 120

Tire Size	TT/TL	Load/Speed Index	Rims		Inflated Dimensions (No Load)		Inflated Dimensions (W/Load)		Inflation Pressure (psi/bar)	Load capacity per tire, kg			
			Recom (inch)	Permitted (inch)	Section Width (mm)	Outer Diameter (mm)	Dynamic Rolling Circumference (mm)	Static Loaded Radius (mm)		Speed, km/h			
										10	30	40	50
230/95 R40	TL	122 A8 / 122 B	W7	W8	228	1454	4362	684	29 / 2.0	2080	1485	1390	1390
									32 / 2.2	2115	1510	1410	1410
									35 / 2.4	2250	1605	1500	1500
210/95 R44	TL	120 A8 / 120 B	W7	W6	211	1522	4616	723	17 / 1.2	1200	1165	1090	1090
									23 / 1.6	1380	1285	1200	1200
									29 / 2.0	1620	1390	1300	1300
									<b>35 / 2.4</b>	1800	1500	<b>1400</b>	1400
230/95 R44	TL	132 A8 / 132 B	W7	W8	230	1568	4748	733	20 / 1.4	1370	1260	1180	1180
									23 / 1.6	1500	1370	1280	1280
									29 / 2.0	1600	1495	1400	1400
									35 / 2.4	1790	1605	1500	1500
									40 / 2.8	1950	1755	1640	1640
									46 / 3.2	2230	1905	1780	1780
									<b>58 / 4.0</b>	2500	2140	<b>2000</b>	2000
270/95 R44	TL	142 A8 / 142 B	W9	W8, W10	275	1632	4896	770	49 / 3.4	3675	2620	2450	2450
									52 / 3.6	3735	2665	2490	2490
									58 / 4.0	3975	2835	2650	2650
300/95 R46	TL	148 A8 / 148 B	W9	DW10, W10, DW11, W11	295	1738	5214	807	49 / 3.4	-	3565	3100	2900
									54 / 3.7	-	3680	3200	2995
									58 / 4.0	-	3878	3370	3150
230/95 R48	TL	136 A2/ 125 A8	W7	W8	230	1662	5031	796	20 / 1.4	1228	1040	974	-
									23 / 1.6	1344	1130	1056	-
									29 / 2.0	1434	1233	1155	-
									35 / 2.4	1604	1324	1238	-
									40 / 2.8	1747	1448	1353	-
									46 / 3.2	1998	1572	1469	-
58 / 4.0	2240	1765.5	1650	-									

• Load capacity on recommended speed and pressure is stated with dark colour.

### DESCRIPTION

\* For load capacity on various speeds, and inflation figures, please consult your sales representative.

\*\* Load capacity on standard speed and weight

- Our company is entitled to make any change on any information in this catalogue, without further notice.
- This catalogue annuls all the previous catalogues
- All figures are for reference; our company is not responsible for printing errors.



## Row Crop • Characteristics of TA 120

Tire Size	TT/TL	Load/Speed Index	Rims		Inflated Dimensions (No Load)		Inflated Dimensions (W/Load)		Inflation Pressure (psi/bar)	Load capacity per tire, kg			
			Recom (inch)	Permitted (inch)	Section Width (mm)	Outer Diameter (mm)	Dynamic Rolling Circumference (mm)	Static Loaded Radius (mm)		Speed, km/h			
										10	30	40	50
270/95 R48	TL	144 A8 / 144 B	W9	W8, W10	275	1733	5199	821	49 / 3.4	3885	2770	2590	2590
									52 / 3.6	3950	2815	2630	2630
									58 / 4.0	4200	2995	2800	2800
300/95 R52	TL	156 D / 162 A8	W12	W11,W13	380	1852	5556	877	49 / 3.4	-	4180	3910	3720
									52 / 3.6	-	4575	4280	4070
									<b>58 / 4.0</b>	-	4920	4600	<b>4375</b>
270/95 R54	TL	157 A2/ 146 A8	W10	W8,9	275	1890	5721	904	20 / 1.4	2079	1618	1512	-
									23 / 1.6	2534	1972	1843	-
									29 / 2.0	2772	2157	2016	-
									35 / 2.4	2970	2311	2160	-
									40 / 2.8	3247	2527	2362	-
									46 / 3.2	3524	2743	2563	-
									58 / 4.0	3960	3082	2880	-
64 / 4.4	<b>4125</b>	3210	<b>3000</b>	-									
340/85 R48	TL	151 D	W12	W11	343	1797	5199	844	44 / 3.0	-	3490	3325	3190
									46 / 3.2	-	3650	3475	3335
									52 / 3.6	-	3970	3780	3625
380/90 R46	TL	159 D/ 162 A8	W12	W11, W13	380	1852	5556	877	49 / 3.4	-	4480	4040	4090
									52 / 3.6	-	4680	4420	4270
									58 / 4.0	-	5030	4750	4595

• Load capacity on recommended speed and pressure is stated with dark colour.

### DESCRIPTION

\* For load capacity on various speed ratings, and inflation figures, please consult your sales representative.

\*\* Load capacity on standard speed and weight

- Our company is entitled to make any change on any information in this catalogue, without further notice.
- This catalogue annuls all the previous catalogues
- All figures are for reference; our company is not responsible for printing errors.

**petlas**

Trailer

UN 1

UN 1 5 RIB

UN 3

UN 5

UN 7

STB 3

PA 20

NT 3

NT 30

NB 27

NB 37

NT 3 PA 20



UN 1

UN 1<sub>5 Rib</sub>

UN 3

UN 5

UN 7

STB 3

PA 20

NT 3

NT 30

NB 27

NB 37



# UN1 3 Rib

Trailer

## PERFORMANCE INFORMATION

Heavy load capacity trailer tire with special tread design for fields and short distance roads



## FEATURES

### Long service life / Durability

- Durable nylon carcass structure
- Special tread design
- High resistance against cuts and tread wear with special tread geometry design.

### Heavy load capacity / High performance

- Special tread structure
- High resistance carcass structure
- Triple tread circumferential
- Conic structure
- It squeezes less soil with its wide base area, so provides high load capacity. Self-cleaning property.

## SIZES 7.50-16



Trailer • Characteristics of **UN 1<sup>3</sup> Rib**

Tire Size	PR	TT/TL	Load/Speed Index	Rims		Inflated Dimensions (No Load)		Inflated Dimensions (W/Load)		Inflation Pressure (psi/bar)	Load capacity per tire, kg			
				Recom (inch)	Permitted (inch)	Section Width (mm)	Outer Diameter (mm)	Dynamic Rolling Circumference (mm)	Static Loaded Radius (mm)		Speed, km/h			
											10	30	40	50
7.50-16	10	TT	116/A6	5.50F	4.50E, 5.00F, 6.00F, 6LB	214	787	2375	356	46 / 3.2	1240	1100	1000	860
										52 / 3.6	1350	1235	1125	980
										<b>58 / 4.0</b>	1500	1375	<b>1250</b>	1090

• Load capacity on recommended speed and pressure is stated with dark colour.



## DESCRIPTION

- \* For load capacity on various speed ratings, and inflation figures, please consult your sales representative.
- \*\* Load capacity on standard speed and weight

- Our company is entitled to make any change on any information in this catalogue, without further notice.
- This catalogue annuls all the previous catalogues
- All figures are for reference; our company is not responsible for printing errors.

# UN1 5 Rib

Trailer

## PERFORMANCE INFORMATION

Modern harvester and trailer tire for fields and short distance roads



## FEATURES

### Long life

- Durable nylon carcass structure
- Deep / wide 5 rib tread design on the center
- Strong tread on shoulders
- High resistance against cuts and tread wear thanks to special tread compound.

### Perfect load capacity / Ultimate performance

- Strong carcass structure
- Strong tread on shoulders
- It prevents from slide to sides and sinking to the ground with its wide tread design and high load capacity, and provides a balanced drive.

**SIZES** 19.0/45-17 • 500/50-17 • 15.0/55-17 • 400/60-15.5 • 10.5/65-16 • 340/55-16 • 13.0/65-18 • 10.0/75-15.3 RF  
10.0/75-15.3 • 11.5/80-15.3 RF • 11.5/80-15.3 • 12.5/80-15.3 RF • 12.5/80-15.3 • 340/55-16 • 10.5/80-18



# Trailer Characteristics of UN 1<sup>5</sup> Rib

Tire Size	PR	TT/TL	Load/Speed Index	Rims		Inflated Dimensions (No Load)		Inflated Dimensions (W/Load)		Inflation Pressure (psi/bar)	Load capacity per tire, kg			
				Recom (inch)	Permitted (inch)	Section Width (mm)	Outer Diameter (mm)	Dynamic Rolling Circumference (mm)	Static Loaded Radius (mm)		Speed, km/h			
											10	30	40	50
19.0/45-17	12	TL	141/A8	16.00	-	491	866	2615	388	40 / 2.8	3070	2520	2290	2015
										46 / 3.2	3280	2690	2445	2150
										<b>48 / 3.3</b>	3450	2830	<b>2575</b>	2265
500/50-17	10	TL	143/A8	16.00	-	503	932	2846	420	23 / 1.6	3005	2550	2315	2015
										26 / 1.8	3220	2730	2480	2155
										<b>29 / 2.0</b>	3540	3000	<b>2725</b>	2370
	35 / 2.4	3595	2930							2665	2315			
	14	TL	149/A8							38 / 2.6	3905	3180	2890	2515
										<b>41 / 2.8</b>	4390	3575	<b>3250</b>	2825
15.0/55-17	14	TL	137/A8	13.00	13	391	850	2467	370	40 / 2.8	2490	2050	1860	1640
										46 / 3.2	2710	2225	2025	1780
										<b>52 / 3.6</b>	3080	2530	<b>2300</b>	2025
400/60-15.5	14	TL	145/A8	AG13.00	-	404	874	2661	390	40 / 2.8	3145	2580	2350	2060
										46 / 3.2	3380	2775	2520	2215
										<b>52 / 3.6</b>	3885	3190	<b>2900</b>	2550
10.5/65-16	10	TT	123/A8	W9	W8-W8L	274	755	2302	345	46 / 3.2	1745	1895	1720	1515
										52 / 3.6	1930	2065	1335	1650
										<b>55 / 3.8</b>	2075	1705	<b>1550</b>	1365
340/55-16	12	TL	140/A8	11	-	343	780	2325	735	49 / 3.4	3045	2435	2170	1955
										52 / 3.6	3185	2550	2275	2045
										<b>58 / 4.0</b>	3500	2800	<b>2500</b>	2250

\* Load capacity on recommended speed and pressure is stated with dark colour.

## DESCRIPTION

\* For load capacity on various speed ratings, and inflation figures, please consult your sales representative.

\*\* Load capacity on standard speed and weight

- Our company is entitled to make any change on any information in this catalogue, without further notice.
- This catalogue annuls all the previous catalogues
- All figures are for reference; our company is not responsible for printing errors.



Trailer Characteristics of **UN 1<sup>5</sup> Rib**

Tire Size	PR	TT/TL	Load/Speed Index	Rims		Inflated Dimensions (No Load)		Inflated Dimensions (W/Load)		Inflation Pressure (psi/bar)	Load capacity per tire, kg			
				Recom (inch)	Permitted (inch)	Section Width (mm)	Outer Diameter (mm)	Dynamic Rolling Circumference (mm)	Static Loaded Radius (mm)		Speed, km/h			
											10	30	40	50
13.0/65-18	12	TT	138/A8	11	-	336	890	2828	420	40 / 2.8	2580	2100	1910	1680
										46 / 3.2	2800	2285	2075	1825
										<b>52 / 3.6</b>	3185	2595	<b>2360</b>	2075
	14	TT	141/A8							50 / 3.6	2945	2435	2215	1945
										58 / 4.0	3150	2605	2370	2085
										<b>63 / 4.3</b>	3425	2830	<b>2575</b>	2265
10.0/75-15.3 REINFORCED	10	TL	123/A8	9.00	-	264	760	2368	352	46 / 3.2	1745	1430	1300	1145
										52 / 3.6	1910	1570	1425	1255
										<b>56 / 3.9</b>	2075	1705	<b>1550</b>	1365
	12	TL	126/A8							52 / 3.6	1905	1550	1410	1240
										58 / 4.0	2110	1720	1565	1375
										<b>68 / 4.7</b>	2295	1870	<b>1700</b>	1495
10.0/75-15.3	10	TT	123/A8	9.00	-	264	760	2368	352	46 / 2.0	1745	1430	<b>1300</b>	1145
										52 / 4.0	1910	1570	<b>1425</b>	1255
										<b>56 / 3.9</b>	2075	1705	<b>1550</b>	1365
	12	TL	123/A8							52 / 3.6	1905	1550	<b>1410</b>	1240
										58 / 4.0	2110	1720	<b>1565</b>	1375
										<b>68 / 4.7</b>	2295	1870	<b>1700</b>	1495
	14	TL	130/A8							75 / 5.2	2190	2070	<b>1950</b>	1740
										84 / 5.8	2315	2190	<b>2060</b>	1840
										<b>92 / 6.3</b>	2465	2325	<b>2190</b>	1955
11.5/80-15.3 REINFORCED	12	TL	135/A8	9.00	-	290	845	2600	382	46 / 3.2	2275	1895	1720	1515
										52 / 3.6	2480	2065	1875	1650
										<b>60 / 4.1</b>	2880	2400	<b>2180</b>	1915

• Load capacity on recommended speed and pressure is stated with dark colour.

**DESCRIPTION**

\* For load capacity on various speeds, and inflation figures, please consult your sales representative.

\*\* Load capacity on standard speed and weight

• Our company is entitled to make any change on any information in this catalogue, without further notice.

• This catalogue annuls all the previous catalogues

• All figures are for reference; our company is not responsible for printing errors.



Trailer • Characteristics of **UN 1<sup>5</sup> Rib**

Tire Size	PR	TT/TL	Load/Speed Index	Rims		Inflated Dimensions (No Load)		Inflated Dimensions (W/Load)		Inflation Pressure (psi/bar)	Load capacity per tire, kg									
				Recom (inch)	Permitted (inch)	Section Width (mm)	Outer Diameter (mm)	Dynamic Rolling Circumference (mm)	Static Loaded Radius (mm)		Speed, km/h									
											10	30	40	50						
11.5/80-15.3	12	TT	135/A8	9.00	-	290	845	2600	382	46 / 3.2	2275	1895	1720	1515						
										52 / 3.6	2480	2065	1875	1650						
										<b>60 / 4.1</b>	2880	2400	<b>2180</b>	1915						
	12	TL	135/A8							46 / 3.2	2275	1895	1720	1515						
										52 / 3.6	2480	2065	1875	1650						
										<b>60 / 4.1</b>	2880	2400	<b>2180</b>	1915						
12.5/80-15.3 REINFORCED	12	TL	139/A8	900	-	307	889	2571	378	40 / 2.8	2695	2215	2015	1775						
										46 / 3.2	2955	2430	2210	1945						
										<b>54 / 3.7</b>	3250	2670	<b>2430</b>	2135						
12.5/80-15.3	12	TL	139/A8							9.00	-	307	889	2650	390	40 / 2.8	2695	2215	<b>2015</b>	1775
																46 / 3.2	2955	2430	<b>2210</b>	1945
																<b>54 / 3.7</b>	3250	2670	<b>2430</b>	2138
	16	TL	144/A8	54 / 3.7	3225	2650	<b>2408</b>	2120												
				60 / 4.1	3525	2895	<b>2632</b>	2315												
				<b>71 / 4.9</b>	3750	3080	<b>2800</b>	2465												
10.5/80-18	10	TT	131/A8	W9	W8-9	274	885	2768	412	40 / 2.8	2185	1780	1620	1420						
										46 / 3.2	2395	1950	1775	1560						
										<b>54 / 3.7</b>	2635	2145	<b>1950</b>	1715						
	12	TT	137/A8							46 / 3.2	2495	2050	1865	1640						
										52 / 3.6	2680	2200	2000	1760						
										<b>60 / 4.1</b>	3080	2530	<b>2300</b>	2020						
										50 / 3.6	2665	2185	1985	1750						
										58 / 4.0	2840	2330	2120	1865						
										<b>65 / 4.5</b>	3550	2915	<b>2650</b>	2330						
										14	TT	142/A8								

\* Load capacity on recommended speed and pressure is stated with dark colour.

## DESCRIPTION

\* For load capacity on various speed ratings, and inflation figures, please consult your sales representative.

\*\* Load capacity on standard speed and weight

- Our company is entitled to make any change on any information in this catalogue, without further notice.
- This catalogue annuls all the previous catalogues
- All figures are for reference; our company is not responsible for printing errors.

# UN 3 Trailer

## PERFORMANCE INFORMATION

Heavy load capacity trailer tire (for modern agriculture) with special tread design for fields and short distance roads



## FEATURES

### Long service life /Durability

- Durable nylon carcass structure
- Special tread design
- High resistance against cuts and tread wear with special tread geometry design.

### Heavy load capacity / High performance

- Special tread structure
- High resistance carcass structure
- It squeezes less soil with its wide base area, so provides high traction on soft surfaces. It provides perfect balance also on soft surfaces by preventing slide to sides.

## SIZES

10.0/75-15.3 • 10.0/75-15.3 REINFORCED • 10.0/80-12 • 11.5/80-15.3 REINFORCED  
11.5/80-15.3 • 12.5/80-15.3 REINFORCED • 12.5/80-15.3 • 260/70-15.3



## Trailer • Characteristics of UN 3

Tire Size	PR	TT/TL	Load/ Speed Index	Rims		Inflated Dimensions (No Load)		Inflated Dimensions (W/Load)		Inflation Pressure (psi/bar)	Load capacity per tire, kg			
				Recom (inch)	Permitted (inch)	Section Width (mm)	Outer Diameter (mm)	Dynamic Rolling Circumference (mm)	Static Loaded Radius (mm)		Speed, km/h			
											10	30	40	50
10.0/75-15.3	10	TT/TL	123/A8	900	-	264	760	2360	348	46 / 3.2	1745	1430	1300	1145
										52 / 3.6	1910	1570	1425	1255
										<b>56 / 3.9</b>	2075	1705	<b>1550</b>	1365
	12	TL	126/A8							52 / 3.6	1905	1550	1410	1240
										58 / 4.0	2110	1720	1565	1375
										<b>68 / 4.7</b>	2295	1870	<b>1700</b>	1495
10.0/75-15.3 REINFORCED	10	TL	123/A8	9.00	-	264	760	2360	348	46 / 3.2	1745	1430	1300	1145
										52 / 3.6	1910	1570	1425	1255
										<b>56 / 3.9</b>	2075	1705	<b>1550</b>	1365
10.0/80-12	10	TT/TL	122/A8	W8	7.00- 9.00	264	730	2235	322	46 / 3.2	1690	1385	1260	1110
										52 / 3.6	1830	1500	1365	1200
										<b>57 / 3.9</b>	2010	1650	<b>1500</b>	1320
11.5/80-15.3 REINFORCED	12	TL	137/A8	900	-	290	845	2506	376	46 / 3.2	2400	1975	1795	1580
										52 / 3.6	2495	2050	1860	1640
										<b>60 / 4.1</b>	3080	2530	<b>2300</b>	2025
11.5/80-15.3	12	TT/ TL	135/A8	9.00	-	290	845	2506	376	46 / 3.2	2400	1975	1795	1580
										52 / 3.6	2495	2050	1860	1640
										<b>60 / 4.1</b>	2080	2530	<b>2300</b>	2025
12.5/80-15.3 REINFORCED	12	TL	141/A8	900	-	307	889	2630	386	40 / 2.8	2860	2350	2135	1900
										46 / 3.2	3140	2580	2340	2085
										<b>54 / 3.7</b>	3450	2835	<b>2575</b>	2290
12.5/80-15.3	14	TL	142/A8	900	-	307	889	2630	386	46 / 3.2	2805	2300	2095	1840
										52 / 3.6	3050	2505	2280	2005
										<b>62 / 4.3</b>	3550	2915	-	2330
	16	TL	144/A8							52 / 3.6	2985	2525	2295	2040
										58 / 4.0	3240	2740	2490	2215
										<b>71 / 4.9</b>	3640	3080	-	2490
260/70-15.3	12	TT	126/A8	9.00	-	268	753	2236	335	40 / 2.8	1980	1625	1480	1300
										46 / 3.2	2160	1775	1615	1420
										<b>52 / 3.6</b>	2275	1870	<b>1700</b>	1495

• Load capacity on recommended speed and pressure is stated with dark colour.

### DESCRIPTION

\* For load capacity on various speed ratings, and inflation figures, please consult your sales representative.

\*\* Load capacity on standard speed and weight

- Our company is entitled to make any change on any information in this catalogue, without further notice.
- This catalogue annuls all the previous catalogues
- All figures are for reference; our company is not responsible for printing errors.

# UN 5 Trailer

## PERFORMANCE INFORMATION

Heavy load capacity trailer tire with special tread design for fields and short distance roads



## FEATURES

### Long service life /Durability

- Durable nylon carcass structure
- Special tread design
- High resistance against cuts and tread wear with special tread geometry design.

### Heavy load capacity / High performance

- Special tread structure
- High resistance carcass structure
- It squeezes less soil with its wide base area, so provides high traction on soft surfaces. It provides perfect balance also on soft surfaces by preventing slide to sides.

**SIZES** 10.0/80-12 REINFORCED • 10.0/80-12



## Trailer • Characteristics of UN 5

Tire Size	PR	TT/TL	Load/Speed Index	Rims		Inflated Dimensions (No Load)		Inflated Dimensions (W/Load)		Inflation Pressure (psi/bar)	Load capacity per tire, kg				
				Recom (inch)	Permitted (inch)	Section Width (mm)	Outer Diameter (mm)	Dynamic Radius Cycle (mm)	Radius (mm)		Speed, km/h				
											10	30	40	50	
10.0/80-12 REINFORCED	10	TT/TL	122/A8	W8	7.00-9.00	280	700	2100	316	46 / 3.2	1690	1385	1260	1110	
											52 / 3.6	1830	1500	1365	1200
											<b>57 / 3.9</b>	2010	1650	<b>1500</b>	1320
10.0/80-12	10	TT/TL	122/A8	W8	7.00-9.00	280	700	2100	316	46 / 3.2	1690	1385	1260	1110	
											52 / 3.6	1830	1500	1365	1200
											<b>57 / 3.9</b>	2010	1650	<b>1500</b>	1320

• Load capacity on recommended speed and pressure is stated with dark colour.



### DESCRIPTION

- \* For load capacity on various speed ratings, and inflation figures, please consult your sales representative.
- \*\* Load capacity on standard speed and weight

- Our company is entitled to make any change on any information in this catalogue, without further notice.
- This catalogue annuls all the previous catalogues
- All figures are for reference; our company is not responsible for printing errors.



# UN 7

Trailer

## PERFORMANCE INFORMATION

High speed capability has been developed for implement machines for field and road transport is free-rolling tire



## FEATURES

### Long service life /Durability

- Durable carcass structure.
- High resistance against stubble cuts and tread wear with its special tread compound.
- Superb resistance against cuts and puncture with its reinforced sidewall.

### Heavy load capacity / High performance

- It ensures high performance with its Low Section Height profile design.
- Heavy load capacity with its special carcass design.
- High flotation capability thanks to its wide tread.

## SIZES 9.5L-14SL • 9.5L-15SL • 11L-15SL • 12.5-15SL



## Trailer • Characteristics of UN 7

Tire Size	PR	TT/TL	Load/Speed Index	Rims		Inflated Dimensions (No Load)		Inflated Dimensions (W/Load)		Inflation Pressure (psi/bar)	Load capacity per tire, kg
				Recom (inch)	Permitted (inch)	Section Width (mm)	Outer Diameter (mm)	Dynamic Radius Cycle (mm)	Radius (mm)		Speed, km/h
											50
9.5L-14SL	8	TL	111 B	7LB	8LB	248	243	2192	337	44/3.00	1090
9.5L-15SL	8	TL / TT	112 B	7LB	8LB	250	765	2257	344	44/3.00	1120
	12	TL	121 B							64/4.40	1450
11L-15SL	8	TL	113 B	8LB	10LB	273	780	2293	350	36/2.50	1150
	12	TL	121 B							52/3.60	1450
12.5L-15SL	12	TL	127 B	10LB	-	325	825	2430	371	52/3.60	1750

• Load capacity on recommended speed and pressure is stated with dark colour.

### DESCRIPTION

- \* For load capacity on various speed ratings, and inflation figures, please consult your sales representative.
- \*\* Load capacity on standard speed and weight

- Our company is entitled to make any change on any information in this catalogue, without further notice.
- This catalogue annuls all the previous catalogues
- All figures are for reference; our company is not responsible for printing errors.

# STB 3

Trailer

## PERFORMANCE INFORMATION

High speed capability has been developed for implement machines for field and road transport is free-rolling tire



## FEATURES

### Long service life /Durability

- Durable carcass structure.
- High resistance against stubble cuts and tread wear with its special tread compound.
- Superb resistance against cuts and puncture with its reinforced sidewall.

### Heavy load capacity / High performance

- It ensures high performance with its Low Section Height profile design.
- Heavy load capacity with its special carcass design.
- High flotation capability thanks to its wide tread.

## SIZES 10.0/75-15.3



## Trailer • Characteristics of **STB 3**

Tire Size	PR	TT/TL	Load/Speed Index	Rims		Inflated Dimensions (No Load)		Inflated Dimensions (W/Load)		Inflation Pressure (psi/bar)	Load capacity per tire, kg				
				Recom (inch)	Permitted (inch)	Section Width (mm)	Outer Diameter (mm)	Dynamic Radius Cycle (mm)	Radius (mm)		Speed, km/h				
											20	25	30	40	50
10.0/75-15.3	12	TL	126/A8	9.00	-	264	760	2240	346	58 / 4,0	1780	1680	1580	1410	1270
										61 / 4,2	1950	1840	1735	1550	1390
										68 / 4,7	2140	2025	1905	<b>1700</b>	1530

• Load capacity on recommended speed and pressure is stated with dark colour.



### DESCRIPTION

\* For load capacity on various speed ratings, and inflation figures, please consult your sales representative.

\*\* Load capacity on standard speed and weight

- Our company is entitled to make any change on any information in this catalogue, without further notice.
- This catalogue annuls all the previous catalogues
- All figures are for reference; our company is not responsible for printing errors.

# PA 20

Trailer

## PERFORMANCE INFORMATION

Traction type trailer tire with heavy load capacity for fields and short distance roads



## FEATURES

### Long life

- Durable nylon carcass structure
- Special tread design
- High resistance against cuts and tread wear with special deep geometry design.

### Heavy load capacity / Self Cleaning

- Special tread structure
- Strong carcass structure, high load capacity and self-cleaning property

## SIZES 8.25-20



# Trailer • Characteristics of PA 20

Tire Size	PR	TT/TL	Load/Speed Index	Rims		Inflated Dimensions (No Load)		Inflated Dimensions (W/Load)		Inflation Pressure (psi/bar)	Load capacity per tire, kg			
				Recom (inch)	Permitted (inch)	Section Width (mm)	Outer Diameter (mm)	Dynamic Rolling Circumference (mm)	Static Loaded Radius (mm)		Speed, km/h			
											10	30	40	50
8.25-20	12	TT	130/A6	60	5.00F	224	950	2910	435	58 / 4.0	2040	1795	1635	1435
										72 / 5.0	2220	1960	1785	1570
										<b>78 / 5.4</b>	2375	2090	<b>1900</b>	1670
	14	TT	133/A6							72 / 5.0	2160	2010	1680	1510
										78 / 5.4	2380	2130	1940	1600
										<b>90 / 6.2</b>	2555	2265	<b>2060</b>	1790

• Load capacity on recommended speed and pressure is stated with dark colour.

## DESCRIPTION

\* For load capacity on various speed ratings, and inflation figures, please consult your sales representative.

\*\* Load capacity on standard speed and weight

- Our company is entitled to make any change on any information in this catalogue, without further notice.
- This catalogue annuls all the previous catalogues
- All figures are for reference; our company is not responsible for printing errors.

# NT 3 Trailer

## ■ PERFORMANCE INFORMATION

Traction type trailer tire with heavy resistance for fields and short distance roads. High resistance against cuts and tread wear with special wide / deep geometry design.



## ■ FEATURES

### Long life

- Durable nylon carcass structure
- Special tread design
- Wide and deeper tread design provides high resistance against cuts and tread fatigue

### Heavy load capacity / Self Cleaning

- Special tread structure
- Strong carcass structure, high load capacity and self-cleaning property

■ **SIZES** 9.00-16 • 11.5/80-15.3



## Trailer • Characteristics of NT 3

Tire Size	PR	TT/TL	Load/Speed Index	Rims		Inflated Dimensions (No Load)		Inflated Dimensions (W/Load)		Inflation Pressure (psi/bar)	Load capacity per tire, kg			
				Recom (inch)	Permitted (inch)	Section Width (mm)	Outer Diameter (mm)	Dynamic Rolling Circumference (mm)	Static Loaded Radius (mm)		Speed, km/h			
											10	30	40	50
9.00-16	8	TT	118/A6	6.00F	5.50F, 6LB	247	881	2675	394	29 / 2.0	1230	1105	1005	880
										35 / 2.4	1425	1275	1160	1020
										<b>40 / 2.8</b>	1620	1450	<b>1320</b>	1160
	12	TT/TL	125/A6							47 / 3.2	1645	1450	1320	1160
										52 / 3.6	1810	1595	1450	1275
										<b>58 / 4.0</b>	2060	1815	<b>1650</b>	1450
	14	TT	128/A6							52 / 3.6	1895	1680	1530	1345
										58 / 4.0	2075	1840	1670	1470
										<b>67 / 4.6</b>	2232	1980	<b>1800</b>	1585
	16	TT	131/A6							67 / 4.6	2235	1790	1600	1405
										72 / 5.0	2455	1965	1755	1545
										<b>80 / 5.5</b>	2730	2184	<b>1950</b>	1715
11.5/80-15.3	16	TL	141/A8	9.00	-	290	845	382	2600	75 / 5,2	3080	2770	2615	2465
										81 / 5,6	3370	3040	2870	2700
										<b>90 / 6,2</b>	3710	3340	<b>3150</b>	2970

• Load capacity on recommended speed and pressure is stated with dark colour.



### DESCRIPTION

\* For load capacity on various speed ratings, and inflation figures, please consult your sales representative.

\*\* Load capacity on standard speed and weight

- Our company is entitled to make any change on any information in this catalogue, without further notice.
- This catalogue annuls all the previous catalogues
- All figures are for reference; our company is not responsible for printing errors.

# NT 30

Trailer

## PERFORMANCE INFORMATION

Special trailer tire



## FEATURES

### Long life / Durability

- Durable nylon carcass structure
- Special tread compound for heavy load conditions
- High resistance against cuts and tread wear with special tread geometry design.

### Heavy load capacity / Self Cleaning

- Special tread structure
- Strong carcass structure, high load capacity and self-cleaning property

## SIZES 9.00-16



## Trailer • Characteristics of NT 30

Tire Size	PR	TT/TL	Load/Speed Index	Rims		Inflated Dimensions (No Load)		Inflated Dimensions (W/Load)		Inflation Pressure (psi/bar)	Load capacity per tire, kg			
				Recom (inch)	Permitted (inch)	Section Width (mm)	Outer Diameter (mm)	Dynamic Rolling Circumference (mm)	Static Loaded Radius (mm)		Speed, km/h			
											10	30	40	50
9.00-16	12	TT	125/A6	6.00F	5.50F, 6LB	247	881	2650	388	47 / 3.2	1645	1450	1320	1160
										52 / 3.6	1810	1595	1450	1275
										<b>58 / 4.0</b>	2060	1815	<b>1650</b>	1450
	14	TT	128/A6							52 / 3.6	1895	1680	1530	1345
										58 / 4.0	2075	1840	1670	1470
										<b>67 / 4.6</b>	2235	1980	<b>1800</b>	1585
	16	TT	131/A6							67 / 4.6	2235	1790	1600	1405
										72 / 5.0	2455	1965	1755	1545
										<b>80 / 5.5</b>	2731	2185	<b>1950</b>	1715

• Load capacity on recommended speed and pressure is stated with dark colour.



### DESCRIPTION

- \* For load capacity on various speed ratings, and inflation figures, please consult your sales representative.
- \*\* Load capacity on standard speed and weight

- Our company is entitled to make any change on any information in this catalogue, without further notice.
- This catalogue annuls all the previous catalogues
- All figures are for reference; our company is not responsible for printing errors.

# NB 27

Trailer

## PERFORMANCE INFORMATION

Traction type trailer tire with heavy load capacity for fields and short distance roads



## FEATURES

### Long life / Durability

- Durable nylon carcass structure
- Special tread design
- High resistance against cuts and tread wear with special deep geometry design.

### Heavy load capacity / Self Cleaning

- Special tread geometry provides easy steering
- Flexible carcass structure prevents sinking

## SIZES 9.00-20



## Trailer • Characteristics of NB 27

Tire Size	PR	TT/TL	Load/Speed Index	Rims		Inflated Dimensions (No Load)		Inflated Dimensions (W/Load)		Inflation Pressure (psi/bar)	Load capacity per tire, kg			
				Recom (inch)	Permitted (inch)	Section Width (mm)	Outer Diameter (mm)	Dynamic Rolling Circumference (mm)	Static Loaded Radius (mm)		Speed, km/h			
											10	30	40	50
9.00-20	14	TT	133/A6	6.00F	5.50F, 6LB	247	1017	3040	452	67 / 4.6	2245	1990	1810	1575
										72 / 5.0	2325	2060	1875	1630
										<b>81 / 5.6</b>	2550	2265	<b>2060</b>	1790

• Load capacity on recommended speed and pressure is stated with dark colour.



### DESCRIPTION

\* For load capacity on various speed ratings, and inflation figures, please consult your sales representative.

\*\* Load capacity on standard speed and weight

- Our company is entitled to make any change on any information in this catalogue, without further notice.
- This catalogue annuls all the previous catalogues
- All figures are for reference; our company is not responsible for printing errors.

**petlas**

# NB 37

Trailer

## PERFORMANCE INFORMATION

Traction type trailer tire with heavy load capacity for fields and short distance roads



## FEATURES

### Long life / Durability

- Durable nylon carcass structure
- Special tread design
- High resistance against cuts and tread wear with special deep geometry design

### Heavy load capacity / Self Cleaning

- Special tread structure
- High resistance carcass structure
- Reinforced sidewall
- High load capacity, self-cleaning and high resistance against side impacts

**SIZES** 7.50-16



## Trailer • Characteristics of **NB 37**

Tire Size	PR	TT/TL	Load/Speed Index	Rims		Inflated Dimensions (No Load)		Inflated Dimensions (W/Load)		Inflation Pressure (psi/bar)	Load capacity per tire, kg			
				Recom (inch)	Permitted (inch)	Section Width (mm)	Outer Diameter (mm)	Dynamic Rolling Circumference (mm)	Static Loaded Radius (mm)		Speed, km/h			
											10	30	40	50
7.50-16	12	TT	121/A6	5.50F	4.50E, 5.00F, 6.00F, 6LB	214	787	2370	354	52 / 3.6	1355	1290	1190	1045
										58 / 4.0	1485	1420	1305	1145
										<b>73 / 5.0</b>	1650	1580	<b>1450</b>	1275

• Load capacity on recommended speed and pressure is stated with dark colour.



### DESCRIPTION

\* For load capacity on various speed ratings, and inflation figures, please consult your sales representative.

\*\* Load capacity on standard speed and weight

- Our company is entitled to make any change on any information in this catalogue, without further notice.
- This catalogue annuls all the previous catalogues
- All figures are for reference; our company is not responsible for printing errors.

**petlas**



Harvester

BD 60

BD 65

UN 1





BD 60 | UN 1  
BD 65





# BD 60

Harvester

## PERFORMANCE INFORMATION

General purpose agricultural tire with standard profile and R1 deep tread design for high power-high traction tractors / harvesters.



## FEATURES

### Long life / Durability

- Durable nylon carcass structure
- Special tread design
- High resistance against cuts and tread wear with special tread

### High Traction

- Perfect grip to soil / slide free transmission of power to the ground with tread geometry, designed differently on center and shoulders
- Thanks to the special tread geometry property, this traction level is maintained in the later half-life of the tire

### Self cleaning

- The tire cleans itself by its special tread design

**SIZES** 18.4-30





## Harvester Characteristics of **BD 60**

Tire Size	PR	TT/TL	Load/Speed Index	Rims		Inflated Dimensions (No Load)		Inflated Dimensions (W/Load)		Inflation Pressure (psi/bar)	Load capacity per tire, kg					
				Recom (inch)	Permitted (inch)	Section Width (mm)	Outer Diameter (mm)	Dynamic Rolling Circumference (mm)	Static Loaded Radius (mm)		Speed, km/h					
											10	15	20	25	<b>30</b>	40
18.4-30	14	TT	151/A6	W16L	W15L	467	1550	4590	690	32 / 2.2	4055	3765	3420	3100	2895	2555
										35 / 2.4	4395	4080	3700	3355	3140	2765
										<b>38 / 2.6</b>	4830	4485	4070	3690	<b>3450</b>	3040
	16		153/A6	33 / 2.3	4650	4320	3920	3555	3320	2920						
				36 / 2.5	4805	4460	4045	3670	3430	3015						
				<b>42 / 2.9</b>	5110	4745	4305	3905	<b>3650</b>	3210						

• Load capacity on recommended speed and pressure is stated with dark colour.



### DESCRIPTION

\* For load capacity on various speed ratings, and inflation figures, please consult your sales representative.

\*\* Load capacity on standard speed and weight

- Our company is entitled to make any change on any information in this catalogue, without further notice.
- This catalogue annuls all the previous catalogues
- All figures are for reference; our company is not responsible for printing errors.



# BD 65

Harvester

## PERFORMANCE INFORMATION

Harvester tire



## FEATURES

### Long life / Durability

- Durable nylon carcass structure
- Special tread compound harvester
- High resistance against cuts and tread wear with special tread geometry design.

### High Traction / Self cleaning

- Special tread geometry, designed differently on center and shoulders.
- Perfect grip/high traction and self-cleaning property

### High safety on inclined fields

- Prevention from side rolling / high safety thanks to improved lateral resistance with reinforced sidewall / carcass structure.

**SIZES** 23.1-26 • 23.1-30 • 20.8-38



## Harvester Characteristics of **BD 65**

Tire Size	PR	TT/TL	Load/Speed Index	Rims		Inflated Dimensions (No Load)		Inflated Dimensions (W/Load)		Inflation Pressure (psi/bar)	Load capacity per tire, kg					
				Recom (inch)	Permitted (inch)	Section Width (mm)	Outer Diameter (mm)	Dynamic Rolling Circumference (mm)	Static Loaded Radius (mm)		Speed, km/h					
											10	15	20	25	30	40
23.1-26	12	TT	153/A6	DW20B	-	587	1605	4910	740	20 / 1.4	4290	3980	3630	3275	3060	2685
										22 / 1.5	4650	4320	3940	3545	3320	2910
										<b>25 / 1.7</b>	5110	4745	4330	3900	<b>3650</b>	3200
	14	TL	156/A6							26 / 1.8	4700	4365	3965	3595	3360	2955
										28 / 1.9	5150	4780	4340	3935	3680	3235
										<b>29 / 2.0</b>	5600	5200	4720	4280	<b>4000</b>	3520
	18	TL	162/A6							32 / 2.2	5565	5245	4760	4315	4035	3550
										35 / 2.4	6090	5740	5210	4720	4415	3885
										<b>38 / 2.6</b>	6550	6175	5605	5080	<b>4750</b>	4180
23.1-30	12	TT	151/A6	DW20B	-	587	1705	5090	770	20 / 1.4	4150	3855	3500	3170	2965	2610
										22 / 1.5	4440	4125	3740	3395	3170	2790
										<b>25 / 1.7</b>	4830	4485	4070	3690	<b>3450</b>	3035
	14	TL	154/A6							26 / 1.8	4410	4095	3715	3365	3150	2770
										28 / 1.9	4830	4485	4070	3685	3450	3035
										<b>29 / 2.0</b>	5250	4875	4425	4010	<b>3750</b>	3300
	18	TL	160/A6							32 / 2.2	5290	4915	4460	4045	3780	3325
										35 / 2.4	5795	5380	4885	4430	4140	3645
										<b>38 / 2.6</b>	6300	5850	5310	4815	<b>4500</b>	3960
20.8-38	14	TT/TL	159/A6	W18L	W16L	528	1840	5550	848	29 / 2.0	5084	4720	4283	3885	3630	3195
										32 / 2.2	5515	5120	4645	4212	3935	3465
										<b>34 / 2.3</b>	6125	5688	5160	4680	<b>4375</b>	3850

• Load capacity on recommended speed and pressure is stated with dark colour.

### DESCRIPTION

\* For load capacity on various speed ratings, and inflation figures, please consult your sales representative.

\*\* Load capacity on standard speed and weight

- Our company is entitled to make any change on any information in this catalogue, without further notice.
- This catalogue annuls all the previous catalogues
- All figures are for reference; our company is not responsible for printing errors.



# UN 1

Harvester

## PERFORMANCE INFORMATION

Modern harvester and trailer tire for fields and short distance roads



## FEATURES

### Long life

- Durable nylon carcass structure
- Deep / wide 5 rib tread design on the center
- Strong tread on shoulders
- High resistance against cuts and tread wear thanks to special tread compound.

### Perfect load capacity/ Ultimate performance

- Strong carcass structure
- Strong tread on shoulders
- It prevents from slide to sides and sinking to the ground with its wide tread design and high load capacity, and provides a balanced drive.

## SIZES 12.5/80-18





## Harvester Characteristics of UN 1

Tire Size	PR	TT/TL	Load/Speed Index	Rims		Inflated Dimensions (No Load)		Inflated Dimensions (W/Load)		Inflation Pressure (psi/bar)	Load capacity per tire, kg			
				Recom (inch)	Permitted (inch)	Section Width (mm)	Outer Diameter (mm)	Dynamic Rolling Circumference (mm)	Static Loaded Radius (mm)		Speed, km/h			
											10	30	40	50
12.5/80-18	12	TT	142/A8	W9	11	308	975	2915	431	40 / 2.8	-	2185	1985	1750
										46 / 3.2	3125	2330	2120	1865
										<b>54 / 3.7</b>	<b>3550</b>	<b>2915</b>	<b>2650</b>	<b>2330</b>
	50 / 3.6	3195	2625							2700	2095			
	58 / 4.0	3340	3100							2490	2485			
	<b>65 / 4.5</b>	<b>4020</b>	<b>3300</b>							<b>3000</b>	<b>2640</b>			
14	TT	146/A8												

• Load capacity on recommended speed and pressure is stated with dark colour.



### DESCRIPTION

- \* For load capacity on various speed ratings, and inflation figures, please consult your sales representative.
- \*\* Load capacity on standard speed and weight

- Our company is entitled to make any change on any information in this catalogue, without further notice.
- This catalogue annuls all the previous catalogues
- All figures are for reference; our company is not responsible for printing errors.



Flotation  
Forestry

IMF 18

IMT 18

IMT 08





IMF 18

IMT 18

IMT 08



**petlas**





# IMF 18

Flotation

## ■ PERFORMANCE INFORMATION

High traction general purpose flotation tire with standard profile and deep tread design, developed for heavy working conditions



## ■ FEATURES

### Long life

- Durable nylon carcass structure
- Tread design, developed for soft surfaces
- High resistance against cuts and tread wear thanks to deep and wide tread geometry design.

### Perfect load capacity/ Ultimate performance

- Strong tread structure
- Strong shoulder structure
- With its wide / round tread design and heavy load capacity, it provides perfect balance also on soft surfaces by preventing slide to sides.

■ **SIZES** 12.5/80-15.3 • 400/60-15,5 • 500/60-22,5 • 550/60-22,5 • 600/50-22,5







# IMT 18

Flotation

## PERFORMANCE INFORMATION

High traction general purpose forestry tire with standard profile and deep tread design, developed for heavy working conditions



## FEATURES

### Long life

- Durable nylon carcass structure
- Reinforced tread mixture for forest conditions
- High resistance against cuts and tread wear thanks to deep and wide tread geometry design

### High traction

- Thanks to its tread design, developed differently on center and shoulders, it grips the soil perfectly and prevents the vehicle to slide to sides. This property also provides fuel save
- Wide base area prevents sinking

### High performance

- Resistance against side impacts with strong structure and reinforced sidewall mixture
- Absorbs side impacts with its special sidewall mixture and grips the soil perfectly and prevents the vehicle to slide to sides

**SIZES** 400/60-15.5 • 500/60-22.5 • 550/60-22.5 • 600/50-22.5







# IMT 08

Flotation

## PERFORMANCE INFORMATION

High traction general purpose forestry tire with standard profile and deep tread design, developed for heavy working conditions



## FEATURES

### Long life

- Durable nylon carcass structure
- Reinforced tread mixture for forest conditions
- High resistance against cuts and tread wear thanks to deep and wide tread geometry design

### High traction

- Thanks to its tread design, developed differently on center and shoulders, it grips the soil perfectly and prevents the vehicle to slide to sides. This property also provides fuel save
- Wide base area prevents sinking

### High performance

- Resistance against side impacts with strong structure and reinforced sidewall mixture
- Absorbs side impacts with its special sidewall mixture and grips the soil perfectly and prevents the vehicle to slide to sides

**SIZES** 500/60-22.5 • 550/60-22.5 • 600/50-22.5



# Flotation • Characteristics of IMT 08

Tire Size	PR	TT/TL	Load/Speed Index		Rims		Inflated Dimensions		Load index										Loading Applications in Free Rolling				Loading Applications in Drive Wheel				
			Free Rolling	Drive Wheel	Recom (inch)	Permitted (inch)	Section Width (mm)	Outer Diameter (mm)	Inflation Pressure (psi/bar)	Free Rolling (kg)					Drive Wheel (kg)					High Load Variation (HLV)		High Load Variation (HLV)					
										10 km/h	25 km/h	30 km/h	40 km/h	50 km/h	10 km/h	25 km/h	30 km/h	40 km/h	50 km/h	25 km/h	40 km/h	25 km/h	40 km/h				
			Load Capacity (kg)	Inflation Pressure (kg)	Load Capacity (kg)	Inflation Pressure (kg)	Load Capacity (kg)	Inflation Pressure (kg)	Load Capacity (kg)	Inflation Pressure (kg)	Load Capacity (kg)	Inflation Pressure (kg)	Load Capacity (kg)	Inflation Pressure (kg)	Load Capacity (kg)	Inflation Pressure (kg)											
500/60-22.5	10	TL	153/A8	141/A8	AG 16.00	15.00, 16.00, 17.00	503	1172	24/1.7	4560	3910	3680	3285	2955	3245	2755	2595	2315	2085	5210	33	4380	33	4380	33	3680	33
									26/1.8	4750	4040	3800	3395	3055	3350	2850	2680	2395	2155								
									29/2.0	5110	4345	4090	<b>3650</b>	3285	3605	3065	2884	<b>2575</b>	2315								
	16	TL	159/A8	147/A8	AG 16.00	15.00, 16.00, 17.00	503	1172	38/2.6	5510	4685	4410	3935	3540	4090	3475	3270	2920	2630	6245	50	5250	50	5235	50	4395	50
									41/2.8	5940	5050	4750	4245	3820	4175	3550	3340	2980	2685								
									44/3.0	6125	5205	4900	<b>4375</b>	3940	4305	3660	3445	<b>3075</b>	2765								
550/60-22.5	16	TL	167/A8	155/A8	16.00	AG 16.00	537	1232	35/2.4	6715	5705	5370	4795	4315	5150	4380	4120	3680	3310	7780	47	6540	47	6590	47	5540	47
									38/2.6	7170	6095	5740	5120	4610	5260	4470	4210	3760	3380								
									41/2.8	7630	6485	6105	<b>5450</b>	4905	5425	4610	4340	<b>3875</b>	3485								
600/50-22.5	16	TL	156/A8	144/A8	AG 20.00	-	611	1172	32/2.2	4930	4190	3940	3520	3170	3725	3165	2980	2660	2395	5710	43	4800	43	4760	43	4005	43
									35/2.4	5265	4475	4210	3760	3385	3800	3230	3040	2715	2445								
									38/2.6	5600	4760	4480	<b>4000</b>	3600	3920	3330	3135	<b>2800</b>	2520								

- R/F: REINFORCED
- In case full weight of vehicle is twice its empty weight or higher HLV application should be preferred.
- For HLV application, the air pressure should be increased by taking normal use pressure into account. For application values other than the ones on the chart, please refer to your sales representative.
- The distance should not exceed 1 km in HLV applications. For longer distances and faster speeds, please refer to your sales representative.
- Special tread compound provides resistance against cuts.

## DESCRIPTION

- \* For load capacity on various speed ratings, and inflation figures, please consult your sales representative.
- \*\* Load capacity on standard speed and weight

- Our company is entitled to make any change on any information in this catalogue, without further notice.
- This catalogue annuls all the previous catalogues
- All figures are for reference; our company is not responsible for printing errors.





## » W, DW AND TW RIMS

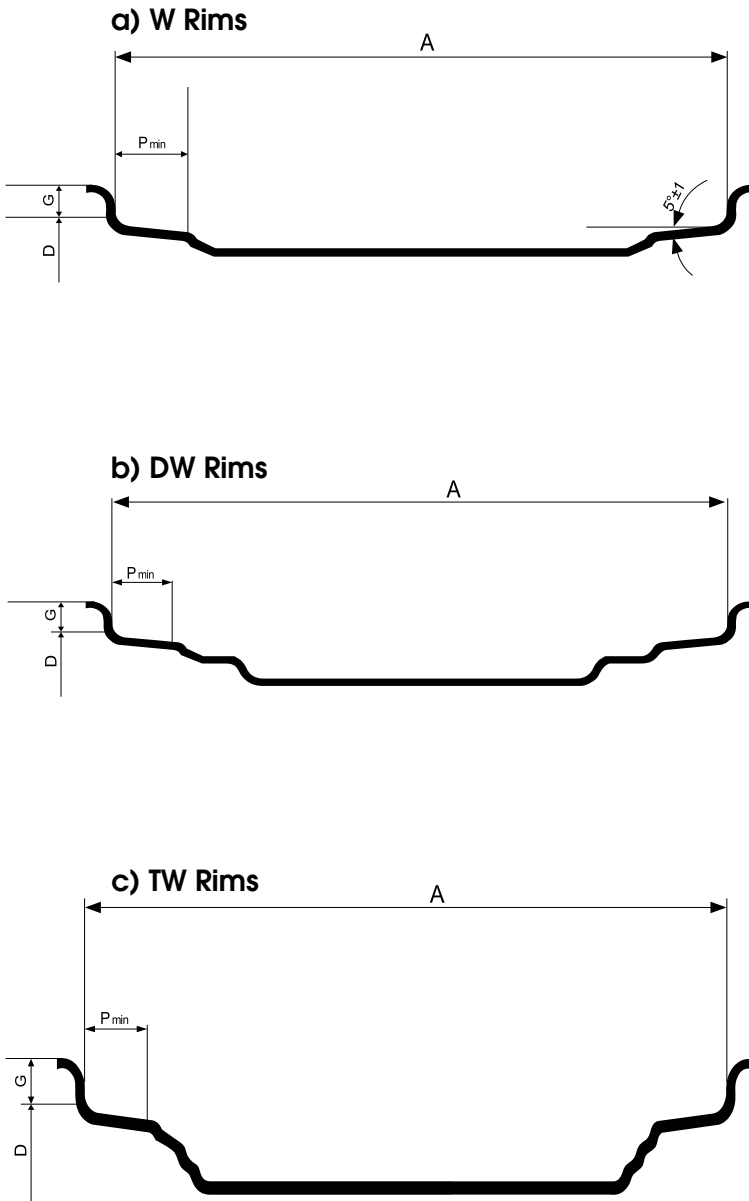

Rim	Dimensions (mm)				
	A	G ± 1	P min.		
W6	152.5	±2.5	23.5		
W7	178		23		
W8	203		23		
W8	203	25.5	27		
W9	228.5				
W10	254				
W11	279.5				
W12	305				
W13	330				
W8L	203				
W10L	254				
W14L	355.5				
W15L	381				
W16L	406.5	±5	33		
W18L	457	25.5	27		
DW10	254				
DW11	279.5				
DW12	305				
DW13	330				
DW13L	330				
DW14L	355.5				
DW15L	381				
DW16L	406.5				
DW18L	457				
DW20B*	508	±6.5	50.5		
DW21B*	533.5				
DW23B*	584				
DW24B*	609.5				
DW25B*	635				
DW27B*	686				
DW28B*	711				
DW30B*	762				
TW13	330			±2.5	27
TW14L	355.5			±5	36.5
TW15L	381				
TW16L	406.5				
TW18L	457				
TW20B	508				
TW21B	533.5				
TW23B	584	±6.5	50.5		
TW24B	609.5				
TW25B	635				
TW27B	686				
TW28B	711				
TW30B	762				

\* It is mentioned as DW-A, now DW-B in current standards.

Rim Diameters	
Nominal Rim Code (*)	Rim Diameter D (mm)
16	405.6
18	462.0
20	512.8
24	614.4
26	665.2
28	716.0
30	766.8
32	817.6
34	868.4
36	919.2

Rim Diameters	
Nominal Rim Code (*)	Rim Diameter D (mm)
38	970.0
40	1020.8
42	1071.6
44	1122.4
66	1173.2
48	1224.0
50	1274.8
52	1325.6
54	1376.4

» 15° DROP-CENTRE RIMS WIDTH CODES AG CONTOUR

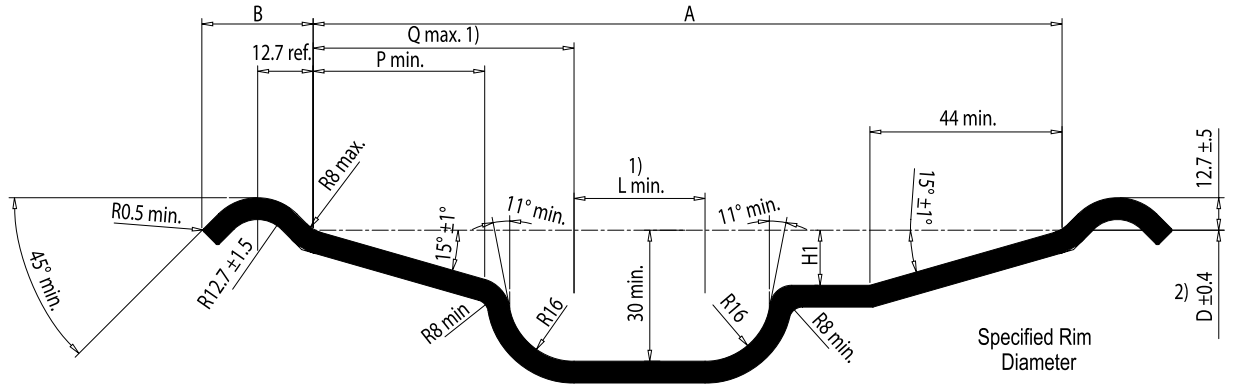

With Code	Dimensions (mm)						Nominal Diameter Code
	A ±5	P min.	Q max.	H1 min.	B min.-max.	L min.	
AG 6.75	171.5	34	70	10	14-17	30	14.5
AG 7.50	190.5	34	70	10	19-29	30	19.5
AG 8.00	203.5	34	70	10	14-17	30	14.5 - 15.5
AG 8.25	209.5	34	70	10	18-27	30	16.5 - 19.5
AG 9.75	247.5	34	70	10	18-27	30	16.5
AG 11.75	298.5	34	70	11	19-29	50	17.5 - 19.5 - 22.5
AG 13.00	330	34	70	11	19-29	50	15.5 - 19.5 - 22.5 - 26.5
AG 14.00	355.5	34	70	11	19-29	50	19.5 - 22.5
AG 16.00	406.5	34	70	11	19-29	50	17.5 - 22.5 - 26.5
AG 20.00	508	44	70	11	19-29	50	22.5 - 24.5 - 26.5 - 30.5
AG 22.00	558.5	44	70	11	19-29	50	24.5
AG 24.00	609.5	44	70	11	19-29	50	22.5 - 24.5 - 26.5 - 30.5
AG 28.00	711	44	70	11	19-29	50	24.5 - 30.5
AG 28.00	711	44	70	11	19-29	50	30.5

Diameters			
Nominal Diameter Code	Specified Diameter D (mm)	Nominal Diameter Code	Specified Diameter D (mm)
14.5	368.3	22.5	571.5
15.5	393.7	22.5	622.3
16.5	419.1	26.5	673.1
17.5	444.5	30.5	774.7
19.5	495.3		



# VALVES

## >>> TUBELESS VALVES

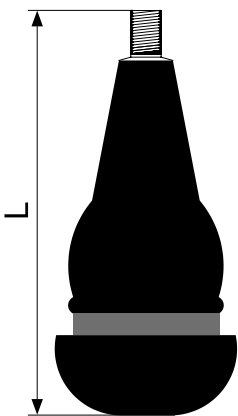

Valve Type, Reference Standard			Valve Diameter	Valve Height (L)
DIN	ETRTO	TRA		
-	V2-03-9	-	8.8	59
43 GS 11.5	V2-03-1	TR413	11.3	42.5
49 GS 11.5	V2-03-2	TR414	11.3	48.5
43 GS 16	V2-03-3	TR415	15.7	42.5

## >>> AIR-WATER VALVE

Valve Parts	Valve Diameter	Valve Height (L)
V5.01.1 ve V4.02.1	15.7	47.5

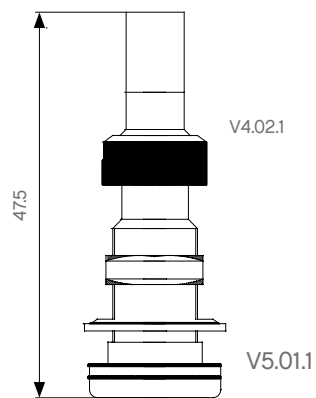

## >>> MATCHING OF SOME VALVE PARTS

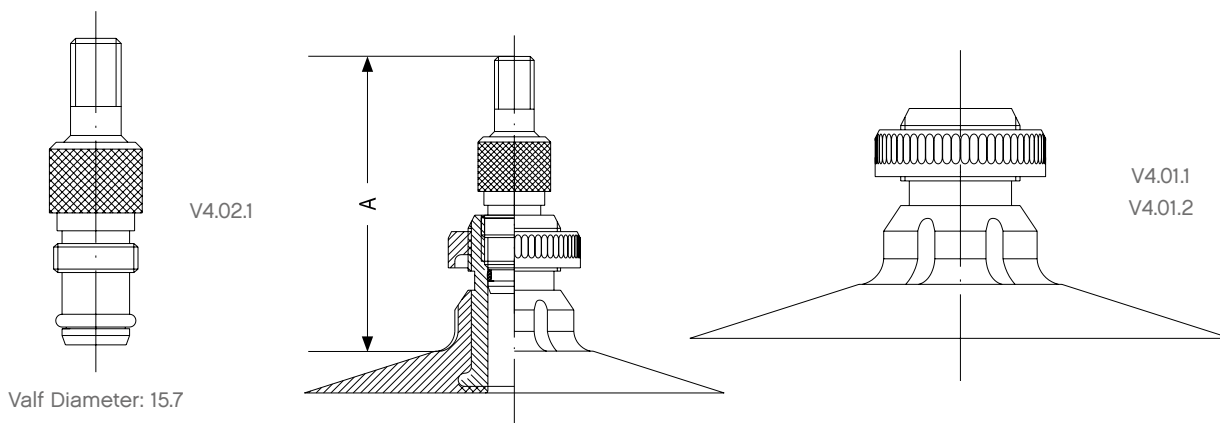

Valf Diameter: 15.7

Valve Type		Parts
V4.03.1	V4.01.1	V4.02.1
V4.03.2	V4.01.2	

Valve Type		A
V4.03.1	V4.01.1	41.15
V4.03.2	V4.01.2	49.65

## ■ MOUNTING AND DISMOUNTING INSTRUCTIONS

- Any mistake in replacement process may cause fatal results, and it must be done at authorized service points with appropriate machinery and by trained staff.
- The rim must be clean and undamaged. Never mount a tire to a cracked, smashed, deformed or repaired/welded rim. Any material which may harm the tire such as oil, rust or dirt must be cleaned. The rim size must be within the tolerance range, recommended by manufacturer of the vehicle.
- The tire must be dry and free of foreign material. In the mounting process, lubricant may be applied on the bead section of the tire. Chemical substances such as petroleum based oils, silicon or detergents must not be used as lubricant. Those products may cause tire to lose its special chemical properties.
- The tire inflation air must be moisture free. After mounting the tire, centering of the tire to the rim must be verified.
- The valves must be brand new and capped. In case the new tire is tube type, a flap must be placed between the tire and the tube. The flap must be powdered before the process.
- New tire must not be matched with old ones.
- In case rotation direction or outer side were stated on the sidewall, this information must be taken into consideration.

## ■ HOW TO INFLATE A TIRE?

- Keep your distance for your safety.
- Use an inflation cage, mounted to the wall or ground, if there is.
- Do not exceed recommended inflation pressure.
- Use a moisture/dirt filter at the pressurized air line to prevent any moisture/dirt inside the tire.
- Do not exceed the recommended inflation pressure during the seating of the bead. In case they do not fit, abort the process.

Incorrect inflation pressure causes following results:

- Decreases the performance of the tire and provides an unsafe and uncomfortable drive. Correct and stable inflation pressure increases the performance and life span of the tire. Inflation pressure must be checked periodically.
- Low inflation pressure decreases the grip, reduces the life span of the tire by overheating, irregular wearing and even separations/cracking at the shoulders and sidewalls. Over inflation pressure causes When the recommended inflation pressure was exceeded, the situation causes the rim to be damaged and vehicle to bounce; the durability against impacts decreases and jeopardises the human life by bursting.
- The fuel consumption increases.
- Causes irregular corrosion on tread.



## STORAGE

- Tire must be stored on special shelves and vertically. In case they are stored vertically one above the other, maximum 8 tire must be put, the tire must be switched each month, in case they remain in this status.
- In the tire storage area, there must not be any material which may create ozone effect such as oil, gasoline, solvent, car battery acid, acid installation system, sodium hydroxide, electrical engine or fluorescent light, even though the tire are already installed on the vehicle.
- The tire storage must be moisture free and must be ventilated regularly, not to cause moisture. There must not be any water in the area.
- In case there is no facility to store the tire on special shelves, their contact with the ground must be prevented and they must be stored one above the other, if they are mounted on rim or vertically, if not mounted on rim.

## USE OF LIQUID BALLAST IN TRACTOR TIRES

The traction of a tire is in direct proportion to its weight. The heavier the tire is, the more traction it has.

In order to increase the traction power and to prevent wear which may occur as a result of slipping, iron cast ballasts must be installed on the front or rear side of the tractor or liquid ballast must be applied. STARMAXX and vehicle manufacturers recommend use of iron cast ballasts. In cases which iron cast ballast application is not possible, tire may be liquid filled.

- Liquid ballasting must be done with a mixture of water /calcium chloride in a way to fill not more than 75 % of the tire.

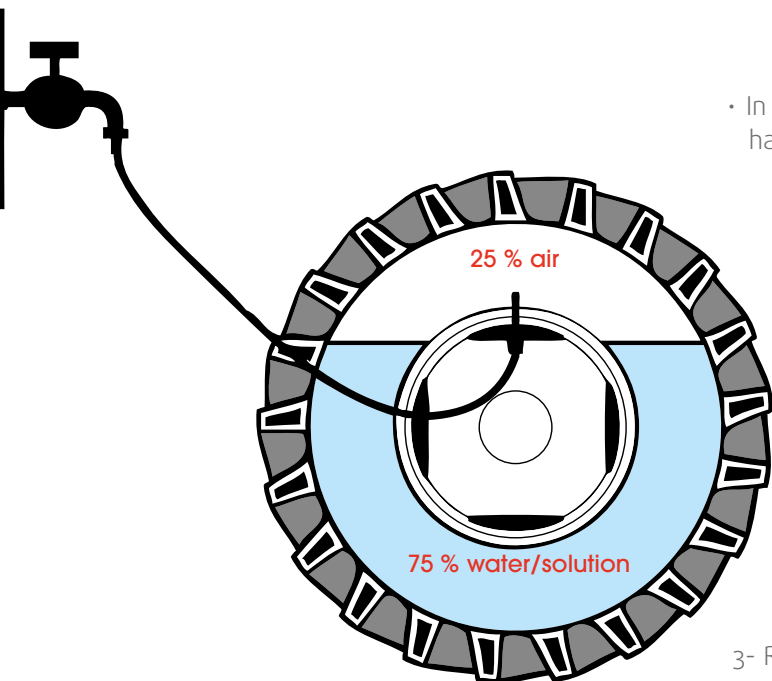

- In case where there is no freezing hazard, only water can be used. However this decreases the effect of ballasting by 20 %. When antifreeze is needed, water /alcium chloride mixture can be used.

- The tire must not be filled with water completely, by any means.

### Liquid Filling Process:

- 1- Deflate the tire.
- 2- Rotate the tire in a way to position the valve at the top.
- 3- Remove the valve core.
- 4- Start filling the water according to the instructions in the manual of the pump.

- 5- During the filling process, remove the pump regularly and let the air get out of the tire.
- 6- Stop the filling process when liquid starts to flow from the valve. Mount the valve core.
- 7- Inflate the tire to its normal pressure.

**Important Remark:**

In tubeless tires, it is recommended to use an inner tube to prevent rim to rust.

**WATER / SOLUTION BALANCING CHART (FOR ONE TIRE)**

Size	Rim	Amount of Solution Required (litre)	Solution preparation	
			CaCl <sub>2</sub> Amount (kg)	Total Weight (kg)
7.50 - 20	5.50 F	30	8	35
9.5 - 20	W8	35	9	41
8.3 - 24	W7	40	11	48
9.5 - 24	W8	50	13	58
11.2 - 24	W10	70	19	81
12.4 - 24	W11	80	22	93
13.6 - 24	DW12	120	32	39
14.9 - 24	W13	150	40	174
18.4 - 26	W16L	280	76	325
23.1 - 26	DW20	470	127	545
11.2 - 28	W10	90	24	104
12.4 - 28	W11	110	30	128
13.6 - 28	W12	140	38	162
14.9 - 28	W13	180	49	209
16.9 - 28	W15L	220	59	255
14.9 - 30	W13	200	54	232
16.9 - 30	W15L	250	67	290
18.4 - 30	W16L	320	86	371
12.4 - 32	W11	130	35	151
16.9 - 34	W15L	280	76	325
18.4 - 34	W16L	360	97	418
12.4 - 36	W11	150	40	174
13.6 - 36	W12	180	49	209
13.6 - 38	W12	190	51	220
14.9 - 38	W12	220	59	255
16.9 - 38	W15L	280	76	325
18.4 - 38	W16L	370	100	429
20.8 - 38	W18L	487	131	565





2017 Edition

DISTRIBUTED BY



**petlas**

**Headquarters - Factory**

Petlas Tire Industry and Trade  
Kırşehir - Kayseri Devlet Yolu Üzeri  
Gölhisar Mevkii 7. km Kırşehir / TURKEY  
T. +90 386 252 65 50 F.+90 386 252 65 70

**Int. Sales & Marketing**

Petlas Tire Industry and Trade  
Kazım Karabekir Cd. Özcan Plaza  
No.124 06060 Ankara / TURKEY  
T. +90 312 309 30 30 F.+90 312 310 95 09

**Petlas Tire USA**

1111 E. Lincolnway STE 205  
Cheyenne, WY 82001 USA

[www.petlas.com](http://www.petlas.com)

**MADE IN TURKEY**